

■ Cutting Angles

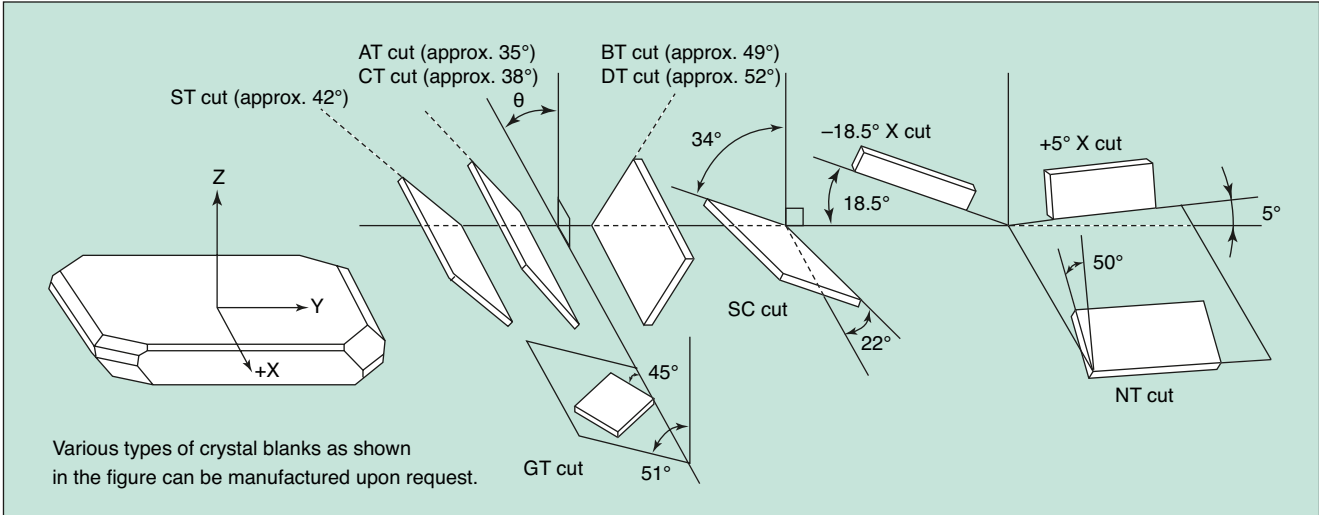

■ AT-cut Plate

Specifications of the most common AT-cut plate are as follows:

● Accuracy of Cutting Angles

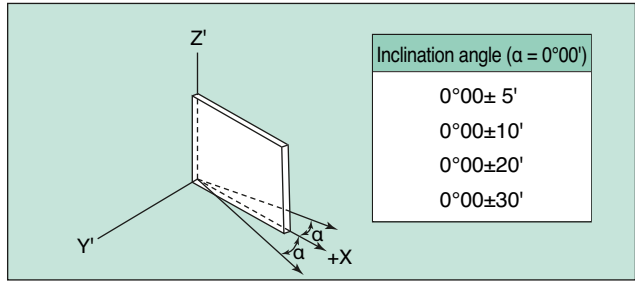
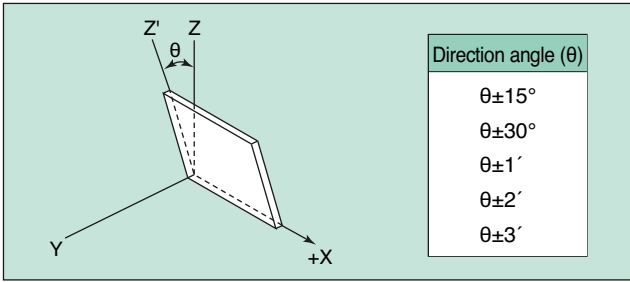

● Coarsely Processed Blank

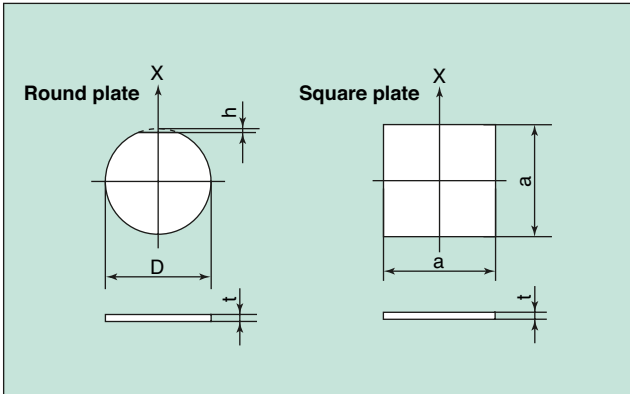

Round plates, square plates, etc. can be manufactured. Coarsely processed blanks are manufactured according to your specifications (cutting angle, etc.). Please feel free to discuss your requirements.