

■ Notes on 2775W/Y and 2785V

● PLL Cascade Connection

2775W/Y-, 2785V-, and 2795-series crystal oscillators output necessary frequencies through the PLL (Phase Locked Loop) circuit, using the crystal oscillation as a reference. Therefore, when the output of this oscillator is connected to a PLL in cascade (when a customer's system contains a PLL circuit and this oscillator is used as the reference of the PLL circuit), jitter may increase.

Particularly when applying the oscillator to image processing or communication synchronization, check the conditions beforehand.

● Output State during Standby

Because the output of 2775W/Y- and 2785V-series crystal oscillators during standby is pulled down (weak pull-down) to GND with a high impedance (typically 500 kΩ), no pull-down resistor for the input section of GATE IC of the next stage is necessary. When the input section of GATE IC of the next stage is pulled up, a pull-up resistor of 10 to 50 kΩ should be used.

■ How to Handle 2700-series Crystal Oscillators

■ Example of Lead-free Soldering Conditions (Infrared Soldering)

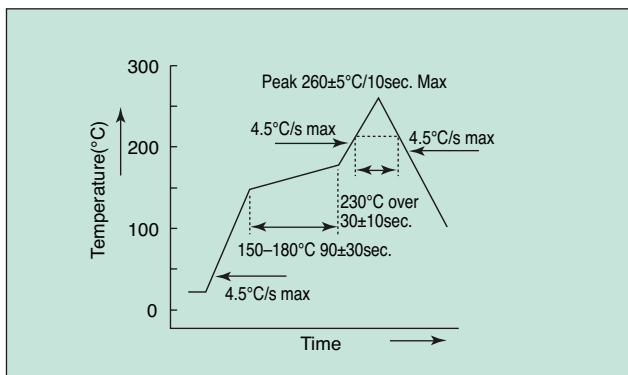

● Soldering conditions

The product's characteristics may deteriorate, depending on soldering conditions. Use the product within the following limitations:

*At 260°C or less within 10 seconds or at 230°C or less within 60 seconds

● Shock resistance

This product has been designed to be highly resistant to shock (it is guaranteed that it will not be damaged when dropped three times from a height of 75 cm onto a hard wooden board or at 29,400/s² in each of the half-wave sine-wave X, Y, and Z directions three times). However, if the unit is dropped by mistake, measure the performance (oscillation check) of the product again.

● Cleaning

Ultrasonic cleaning of this product is possible, but depending on the cleaning conditions the product's oscillator may suffer a resonance fracture. Before ultrasonic cleaning, make sure to check the conditions.

● Others

- Because C-MOS is used for this product, pay great care to static electricity in the same way as for normal C-MOS IC.
- The #2 terminal (GND) is a ground terminal. Therefore, if it is mistaken for the #4 terminal (V_{DD}) and a reverse voltage applied, it may suffer internal fractures. Make sure to connect the terminal correctly.

■ Packing of 2700-series Crystal Oscillators

■ Tape

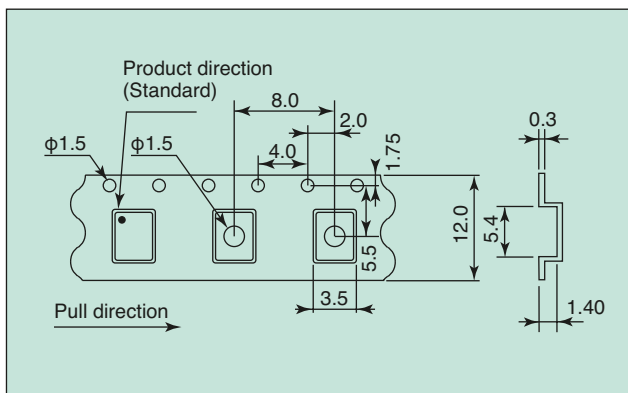

Up to 1,000 pieces per reel are boxed and shipped with the taping method shown above.

■ Reel

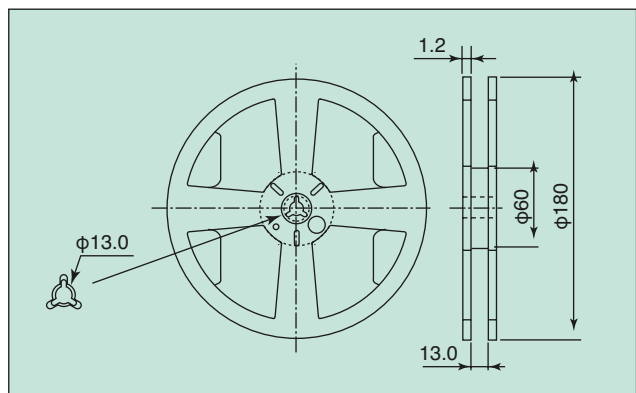

*Note: The packing shown above is the standard method used for a large order.

Packing and shipping of small orders, samples, etc. differs, depending on quantity.

■ Guaranteed Items of 2700 Series

● The environmental and mechanical characteristics of the 2700 Series are guaranteed by conducting the following tests:

No.	Test Items	Conditions	Specifications
1	Thermal shock resistance	100 cycles (one cycle is conducted for 30 minutes at -40°C and for 30 minutes at $+85^{\circ}\text{C}$.)	*1
2	High temperature and high humidity resistance	Subject to a temperature of $+85^{\circ}\text{C}$, in humidity of 80 to 85%, and for 500 hours (nonactive)	*1
3	85°C aging	85°C (nonactive), for 720hours Total amplitude:	*1
4	Vibration resistance	Total amplitude: 1.52 mm or 196 m/s^2 , frequency: 10 to 2,000 Hz, and logarithmic frequency sweep for 20 minutes in each of the three orthogonal directions for four hours (12 hours in total)	*1
5	Shock resistance	Impact acceleration: $29,400\text{ m/s}^2$, impact time: 0.3 ms, and half-wave sine wave in each of the three orthogonal directions, three times	*1
6	Free drop impact resistance	Dropped three times from a height of 75 cm onto a hard wooden board	*1
7	Soldering property	Immersed in a solder bath at a temperature of $+230\pm 5^{\circ}\text{C}$ for 3.5 ± 1 seconds	Ninety-five percent or more of the soldered part must be covered with solder.
8	Soldering heat resistance	Reflow is conducted three times at a warm-up temperature of 180°C for 90 ± 30 seconds and at the peak temperature of $260\pm 5^{\circ}\text{C}$ for up to 10 seconds (at 230°C or more for 30 ± 10 seconds).	*1

(*1) After the above tests have been conducted, the tested product must then meet the electric characteristic specifications. In addition, the change amount of F before and after the above tests must follow $\Delta F/F \leq \pm 10 \times 10^{-6}$.

The electric characteristic specifications refer to the standard specifications of the following items:

(Consumption current, T_r/T_f , V_{OL}/V_{OH} duty cycle, consumption current during standby, and standby function)<

■ 2700-series Package Indications

■ 2700 Series

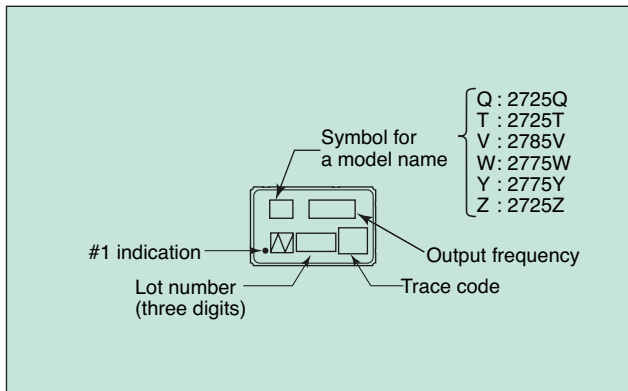

■ 2795 Series

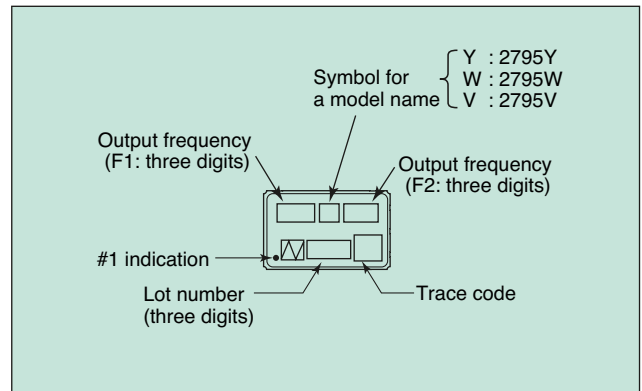

● Because of space limitations, the output frequency is indicated as six digits including the decimal point. Therefore, 14.31818MHz is indicated as 14.318.