

Voltage Controlled Crystal Oscillator

■ NV5032SK Data Sheet

5032 size Multi Mode VCXO

Application

- Base-stations, GbEthernet,
Optical transmission device
- Server

Features

- Supports a wide frequency range : 15 to 2100 MHz
(Frequency tuning resolution: 2×10^{-9})
- Output : LVPECL, LVDS, CML, HCSL
- Frequency Control Range : $\pm 50 \times 10^{-6} \sim \pm 250 \times 10^{-6}$
- Supports low power supply voltage : +1.8 V, +2.5 V, +3.3 V
- Supports narrow stability : $\pm 10 \times 10^{-6}$ 、 $\pm 20 \times 10^{-6}$

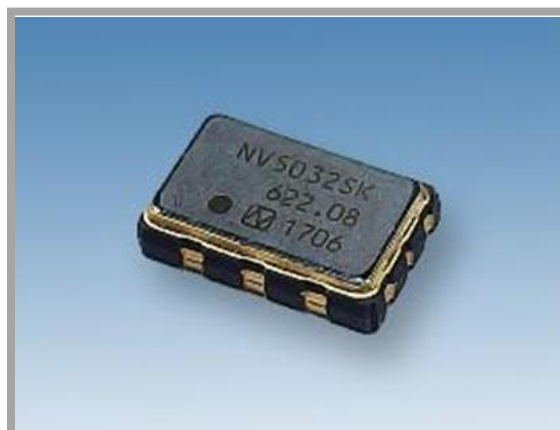

RoHS Compliant
Directive 2011/65/EU
Directive (EU) 2015/863

Pb free

Halogen free

1 Item : Voltage Controlled Crystal Oscillator

2 Type : NV5032SK

3 Nominal Frequency: 15 MHz ~ 2100 MHz

4 NDK Spec. No. : ---

5 Maximum Rating

	Item	Ratings			Notes
		min	max	Units	
1	Supply Voltage	-0.5	+3.8	V	-
2	Control Voltage	-0.5	+3.8	V	-
3	Input Voltage	-0.5	+3.8	V	-
4	Storage Temperature Range	-55	+125	°C	-

6 Electrical Specification

6.1 Common characteristics

Measurement condition: $T=+25\pm 2$ °C, $V_{CC}=+3.3$ V, $V_{cont}=+1.65$ V

	Parameters	SYM	Electrical Spec.			Units	Notes
			Min	Typ.	Max		
1	Supply Voltage	V_{CC}	+2.97	+3.3	+3.63	V	(*1)
2	Control Voltage	V_{cont}	0	+1.65	+3.3		
3	Operating Temperature Range	T_{opr}	-40	-	+85	°C	-
4	Overall Frequency Tolerance		-50	-	+50	ppm	(*2), (*3)
5	Start-up Time	t_{su}	-	-	15	ms	-
6	Symmetry	SYM	45	-	55	%	50 % of waveform
7	Frequency Controlled Characteristics						
	7.1 Frequency Control Range (*4)	$\Delta f/f$	-	-	-100	ppm	$V_{cont}=0$ V
			+100	-	-	ppm	$V_{cont}=V_{CC}$
7.2 Frequency Change Polarity	-	Positive					-

(*1) $V_{CC} = 2.5 V \pm 5\%$ ($V_{cont} = 1.25 V \pm 1.25 V$), $V_{CC} = 1.8 V \pm 5\%$ ($V_{cont} = 0.9 V \pm 0.9 V$) is also available.

(*2) Inclusive of frequency/temperature characteristics, frequency tolerance, frequency/voltage coefficient, long-term frequency stability. (at 10 years)

(*3) Overall Frequency Tolerance of ± 10 ppm and ± 20 ppm are also available.

(*4) Frequency Control Range can be selected from ± 50 ppm to ± 250 ppm.

6.2 Characteristics by output specification

6.2.1 LVPECL

	Parameters	SYM	Electrical Spec.			Units	Notes	
			Min	Typ.	Max			
1	Nominal Frequency	f_{nom}	15	-	2100	MHz	-	
2	Output Load Condition	R_L	-	50	-	Ω	Connect to V_{CC} -2.0 V	
3	Current consumption	I_{CC}	-	-	95	mA	-	
4	Output Voltage	V_{OH}	V_{CC} -1.25	-	-	V	$f_{nom} < 1000$ MHz	
			V_{CC} -1.40	-	-		$f_{nom} \geq 1000$ MHz	
		V_{OL}	-	-	V_{CC} -1.60	-		
5	Rise Time /	t_r / t_f	-	-	400	ps	20 % to 80 % of waveform	$f_{nom} \geq 100$ MHz
	Fall Time		-	-	500			$f_{nom} < 100$ MHz

6.2.2 LVDS

	Parameters	SYM	Electrical Spec.			Units	Notes	
			Min	Typ.	Max			
1	Nominal Frequency	f_{nom}	15	-	2100	MHz	-	
2	Output Load Condition	R_L	-	100	-	Ω	Between Output to Compl. Output	
3	Current consumption	I_{CC}	-	-	85	mA	-	
4	Differential Output Voltage	V_{OD}	247	-	454	mV	$f_{nom} < 700$ MHz	
			150	-	454		$f_{nom} \geq 700$ MHz	
		ΔV_{OD}	-	-	50	-		
5	Offset Voltage	V_{OS}	1.125	-	1.375	V	$V_{CC} = +3.3$ V, +2.5 V	
			0.8	-	1.0		$V_{CC} = +1.8$ V	
		ΔV_{OS}	-	-	50	-		
6	Rise Time /	t_r / t_f	-	-	400	ps	20 % to 80 % of waveform	$f_{nom} \geq 100$ MHz
	Fall Time		-	-	500			$f_{nom} < 100$ MHz

6.3 Output Waveform

6.3.1 LVPECL

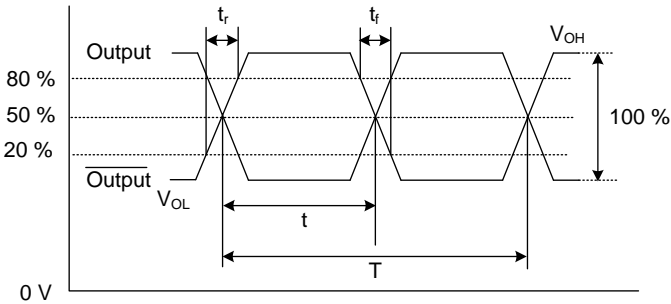

Symmetry = $t/T \times 100\%$

6.3.2 LVDS

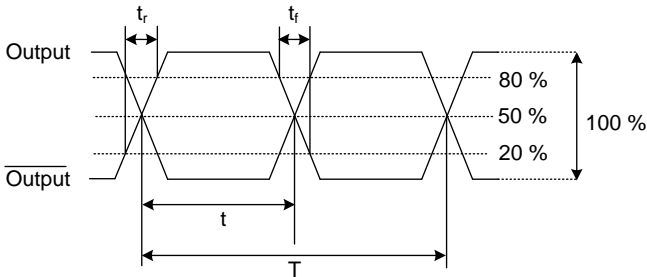
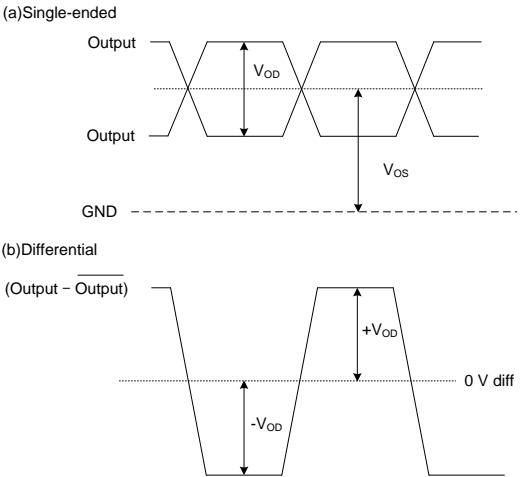

Symmetry = $t/T \times 100\%$

6.4 Measuring Circuits

6.4.1 LVPECL

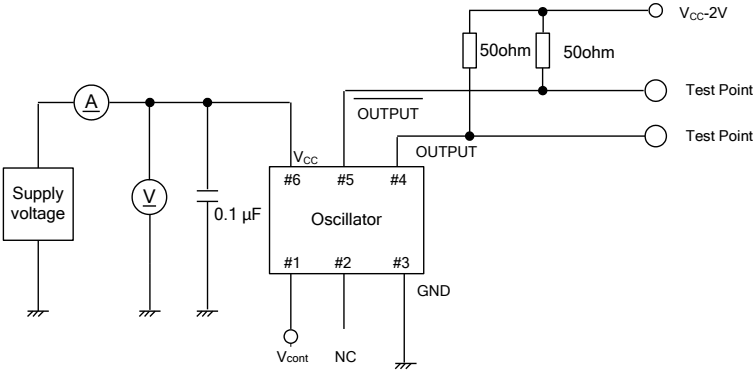

6.4.2 LVDS

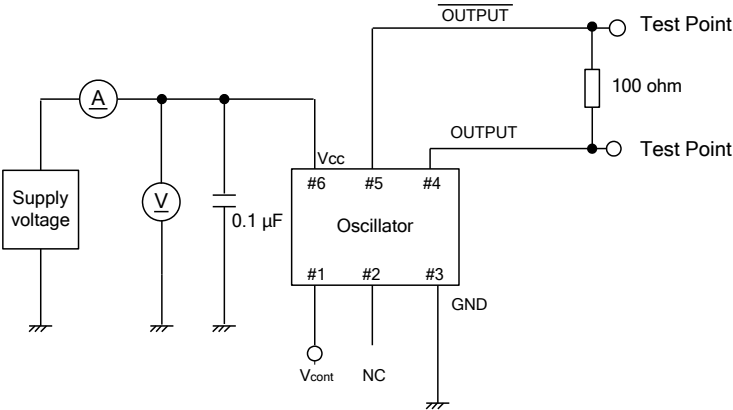

Table.1 Supported frequency list

● mark indicates the currently available frequency

Nominal Frequency [MHz]	Output · Frequency stability			
	LVPECL ±50 ppm	LVDS ±50 ppm	LVPECL ±20 ppm	LVDS ±20 ppm
122.88	●	●		
156.25	●	●		
200	●	●		

■ Necessary information for inquiry

For question or order of this product, please specify following specifications. If you require a product with specifications not given following, please contact NDK sales.

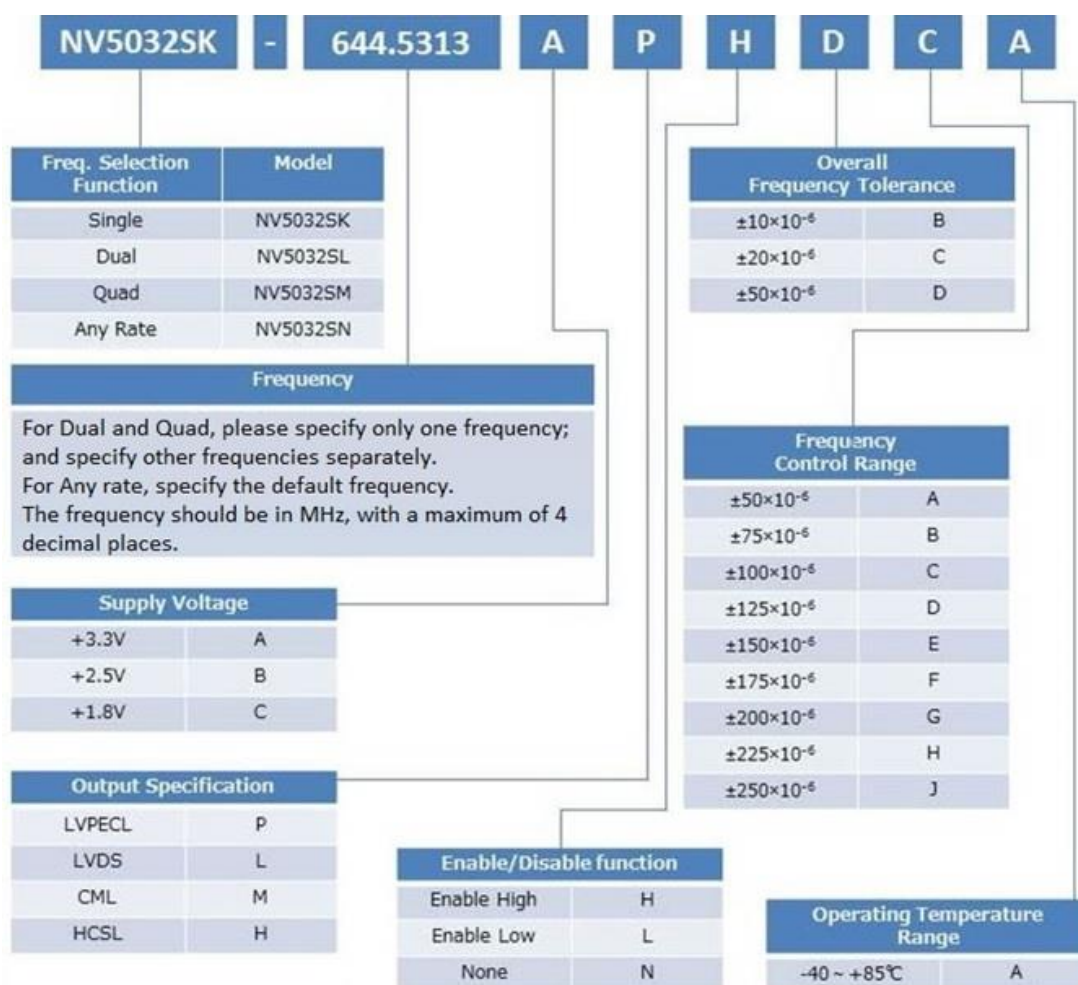

7 Soldering conditions

Example For Soldering Conditions (The below graph corresponds to Pb free solder)

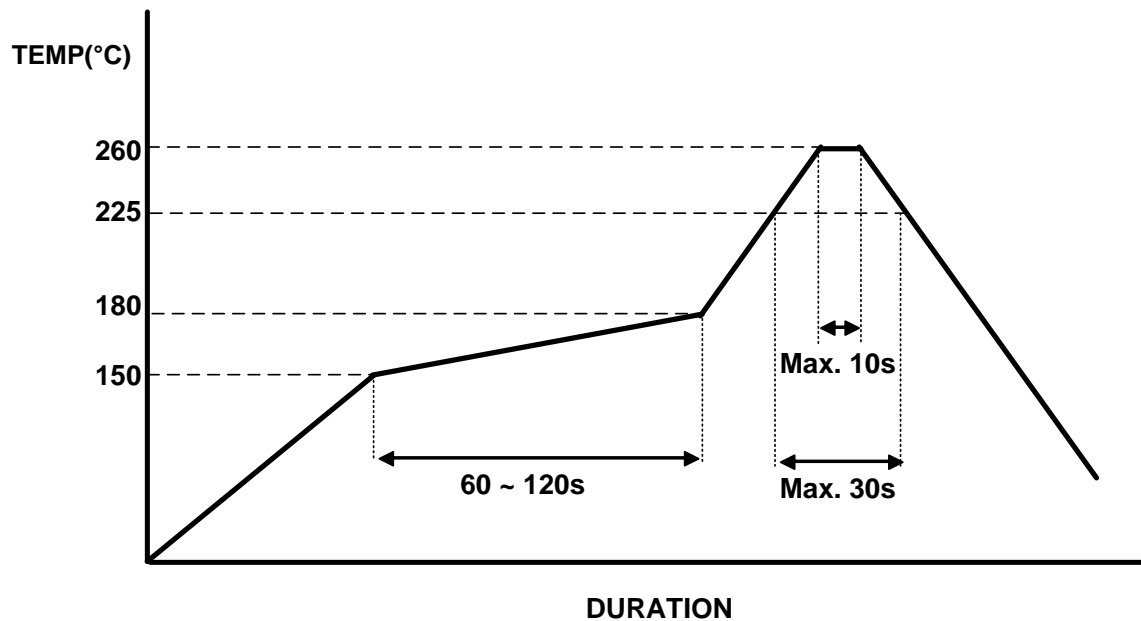

Be sure to use the product under the following conditions. Otherwise, the characteristics deterioration or destruction of the product may result.

(1) Reflow soldering heat resistance

Peak temperature: 260 °C, 10 sec

Heating: 225 °C or higher, 30 sec

Preheating: 150 °C to 180 °C, 120 sec

Reflow passage times: twice

(2) Manual soldering heat resistance

Pressing a soldering iron of 350 °C on the terminal electrode for five seconds (twice).

8 Electro Static Discharge

MM: 200 V

HBM: 2000 V

CDM: 500 V

Dimension of External

Units : mm
Tolerance : 0.1

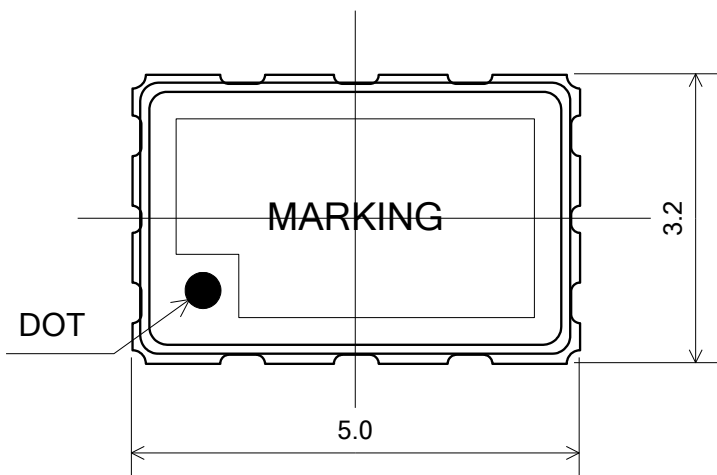

Terminal Land Connections

# 1	V_{cont}
# 2	NC or E/D
# 3	GND
# 4	OUTPUT
# 5	$\overline{\text{OUTPUT}}$
# 6	V_{CC}

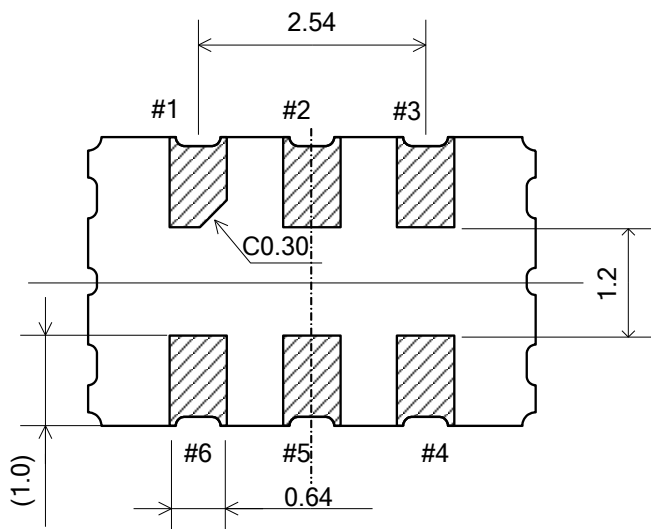
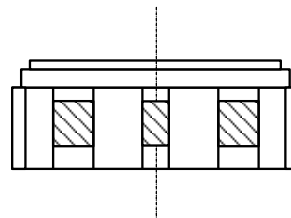
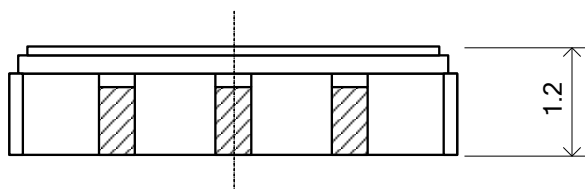

Land pattern (Typical)

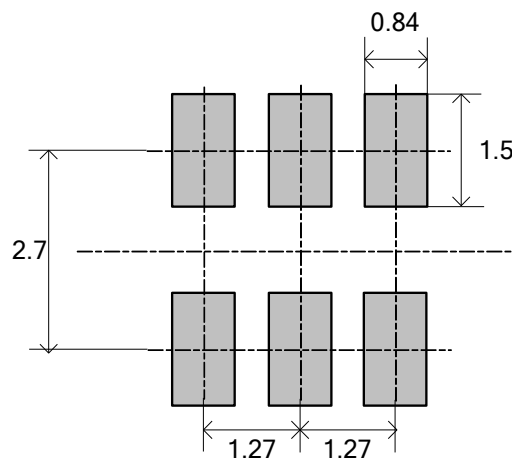

■ Taping and Reel Spec.

1,000 pcs MAX-product Tape

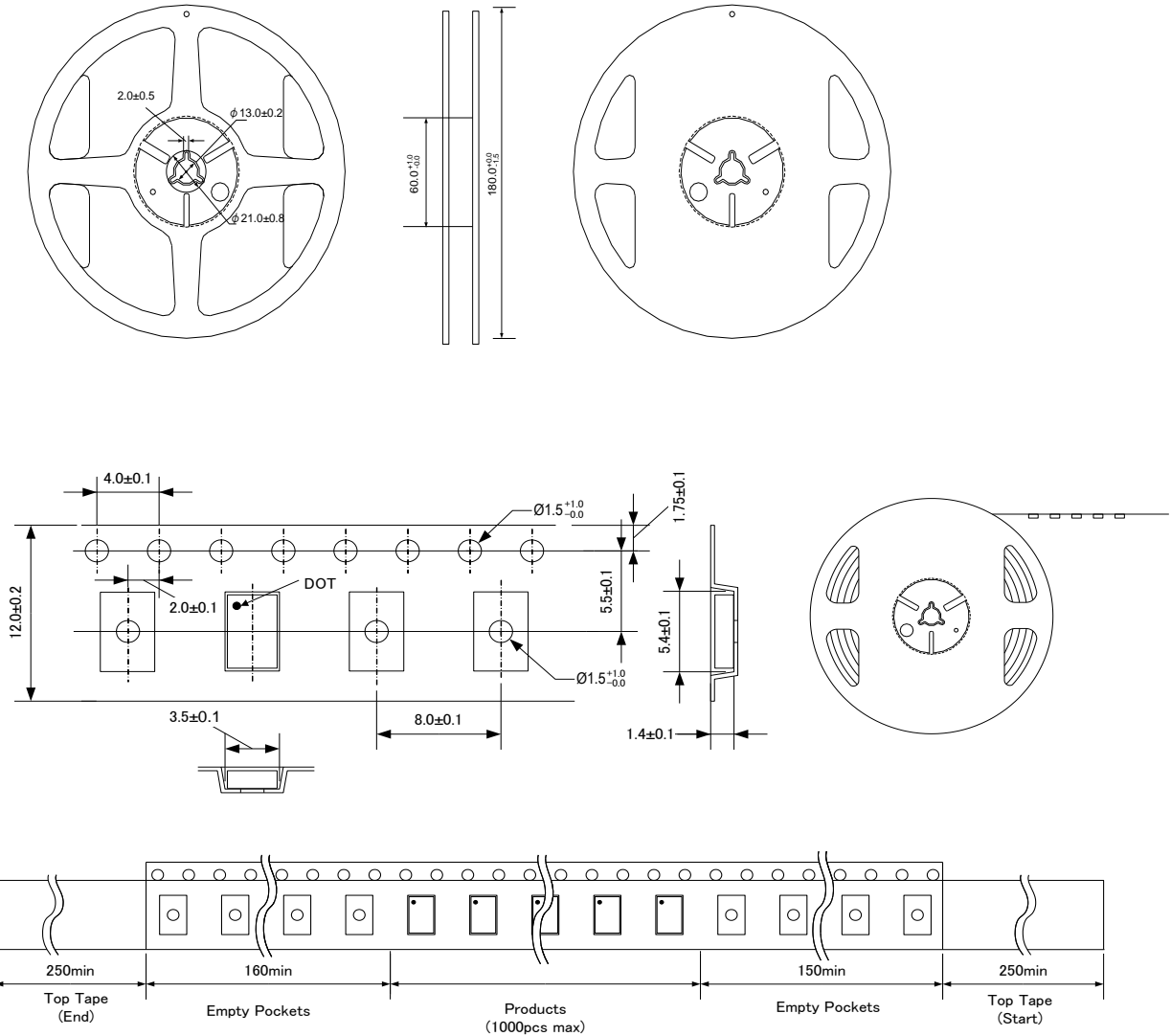

	Reel	Embossed Carrier Tape	Cover Tape
Materials	PS+Carbon	PS+Carbon	PET
Disposition	Antistatic	Antistatic	Antistatic

■ Marking

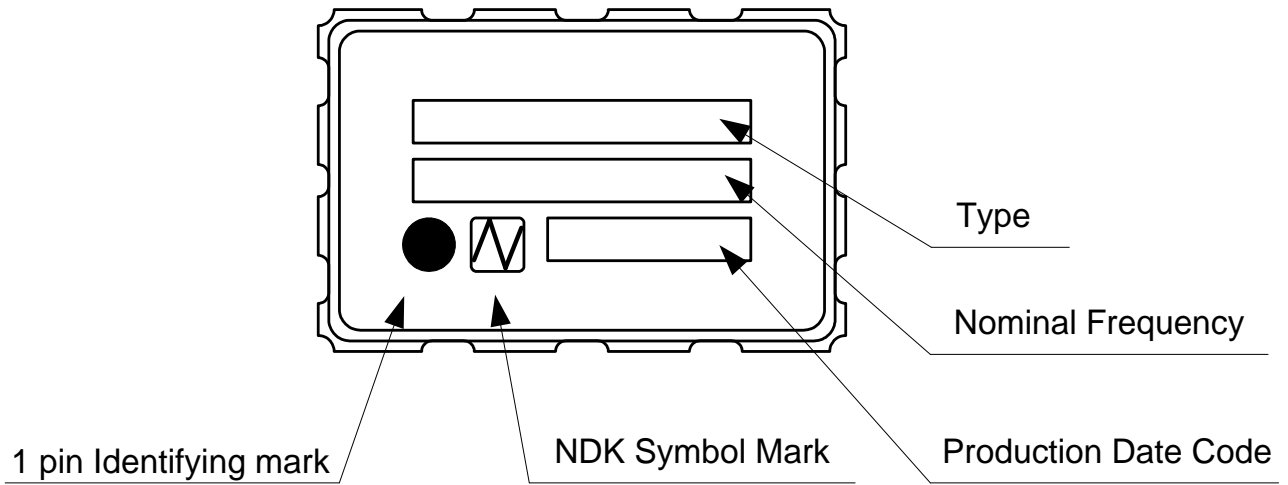

■ Data

Frequency Control Range (± 100 ppm)

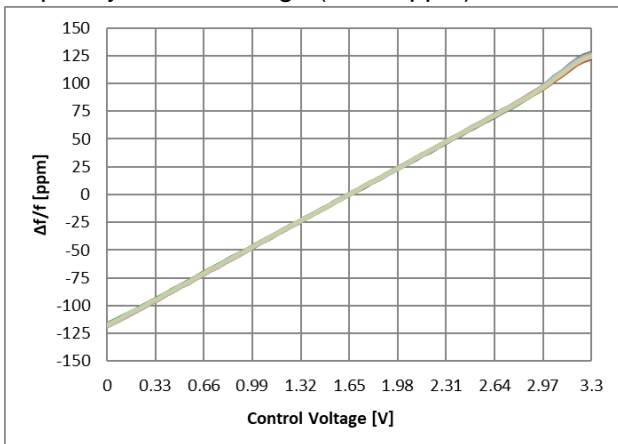

Frequency/Temperature Characteristics (Overall Frequency Tolerance ± 50 ppm)

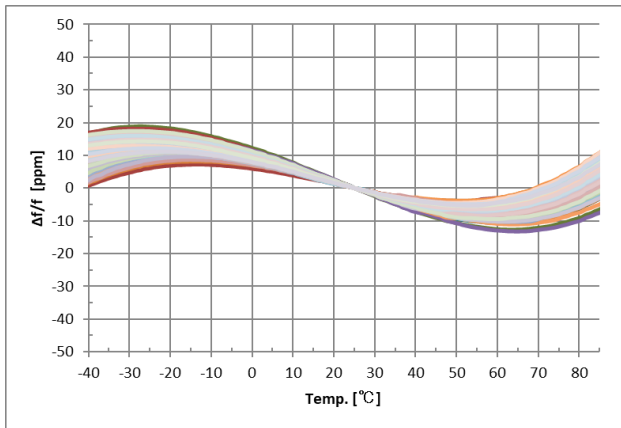

Phase Noise, Phase jitter (PECL 122.88 MHz)

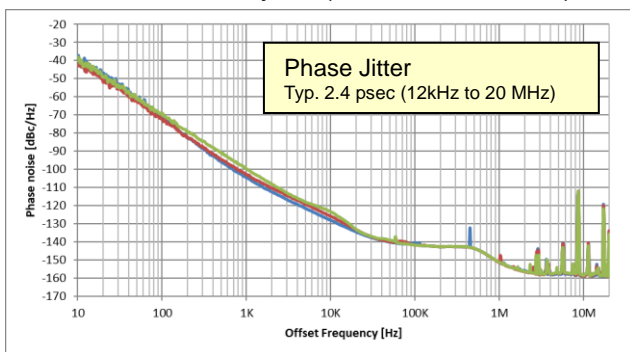

Instruction Notice

1 Noise

When using this product, please insert a bypass capacitor between the power supply and GND.
(Closer to the product terminal is desirable.)

The bypass capacitor values shown in our specifications and drawings are for reference only.
(They are not guaranteed values.)

In actual use, please select the appropriate bypass capacitor value for your circuit.

NDK shall not be liable for any and all events resulting from or in connection with the use of this product in a manner that does not comply with the above instruction.

2 Resistance to dropping

The NV5032S series is designed to be impactproof so that no damage occurs when dropped a height (75 cm) three times. However, if dropped from a desk etc., it is advisable to check their performance or contact us to check it.

3 Electrostatic protection

The NV5032S series employ C-MOS ICs for the active element. Please use them in static-free environments.

4 Cleaning

Basically, the NV5032S series are applicable for ultrasonic wave cleaning. However, in some case, during ultrasonic wave cleanings, internal design may get damage. Please check condition carefully beforehand.

5 Other

The NV5032S series are C-MOS applied products. And careful handling(same as with C-MOS IC) are Needed to avoid electrostatic problems.

Incorrect PAD connection is cause of trouble. Please make sure to connect correctly as below.

#3 terminal → GND

#6 terminal → V_{CC}

Notes On Use

1 Even if the appearance color etc. of the product differs by purchasing the component parts by more than two companies, there is no influence on the characteristics and reliability.

2 IN THE CASE OF THE FOLLOWING ITEMS, WE ARE NOT RESPONSIBLE FOR WARRANTY / COMPENSATION.

(1) WHEN PRODUCTS OF THIS SPECIFICATION ARE USED FOR EQUIPMENT RELATED TO HUMAN LIFE OR PROPERTY, IT IS THE RESPONSIBILITY OF THE CUSTOMER TO CONFIRM THE INFLUENCE ON THIS PRODUCT AND EQUIPMENT TO BE USED BEFOREHAND, CONDUCT NECESSARY SAFETY DESIGN (INCLUDING REDUNDANT DESIGN, MALFUNCTION PREVENTION DESIGN, etc.), PLEASE USE IT AFTER SECURING SUFFICIENT SAFETY OF EQUIPMENT.

1.SAFETY-RELATED EQUIPMENT SUCH AS AUTOMOBILES, TRAINS, SHIPS, etc., OR EQUIPMENT DIRECTLY INVOLVED IN OPERATION

2.AIRCRAFT EQUIPMENT

3.SPACE EQUIPMENT

4.MEDICAL EQUIPMENT

5.MILITARY EQUIPMENT

6.DISASTER PREVENTION / CRIME PREVENTION EQUIPMENT

7.TRAFFIC LIGHT

8.OTHER EQUIPMENT REQUIRING THE SAME PERFORMANCE AS THE ABOVE-MENTIONED EQUIPMENT

(2) IN CASES WHERE IT IS NOT INDICATED IN THE REQUESTED STANDARD AND IS USED UNDER CONDITIONS OF USE (INCLUDING CIRCUIT MARGIN etc.) THAT CAN NOT BE PREDICTED AT THE PRODUCTION STAGE.

(3) WHEN USING ULTRASONIC WELDING MACHINE.(THERE IS A POSSIBILITY THAT THE CHARACTERISTIC DEGRADATION IS CAUSED BY THE RESONANCE PHENOMENON OF THE PIEZOELECTRIC MATERIAL.(EXAMPLE;CRYSTAL PIECE))

WE WILL NOT TAKE ANY RESPONSIBILITY FOR THE INFLUENCE OF THE CUSTOMERS' PROCESS.

SO, PLEASE SUFFICIENTLY EVALUATE AT A SAMPLE STEP WHEN YOU USE ULTRASONIC

WELDING MACHINE.

(4) USING RESIN MOLD MAY AFFECT THE PRODUCT CHARACTERISTIC.

PLEASE MAKE SURE TO TELL OUR SALES CONTACT WHEN YOU USE RESIN MOLD. WE WILL PERFORM INDIVIDUAL CORRESPONDENCE ABOUT A DELIVERY SPECIFICATION AND A EVALUATION METHOD.

IN ADDITION, IF YOU USE RESIN MOLD WITHOUT CONTACTING US, AND CAUSES DAMAGES AGAINST A CUSTOMER OR A THIRD PARTY, WE WILL NOT BE LIABLE FOR THE DAMAGES AND OTHER RESPONSIBILITIES BECAUSE WE CONSIDER IT IS UNDER SELF-RESPONSIBILITY USING RESIN MOLD.

WE WILL NOT TAKE ANY RESPONSIBILITY FOR THE INFLUENCE OF THE CUSTOMERS' PROCESS.

PLEASE EFFICIENTLY EVALUATE AT A SAMPLE STEP WHEN YOU USE RESIN MOLD.

(5) WHEN PERFORMING IMPROPER HANDLING THAT EXCEEDS THE GUARANTEED RANGE.

3 This product can not be used for automotive applications.

We have other products available for automotive applications so please contact us.

Notes on storage

1 When storing the product in high temperature and high humidity condition for a long time, product characteristics (solderability etc.) and packaging condition may be deteriorated. Please store product at temperature + 5 °C ~ + 35 °C, humidity 85 % RH or less. The product is an electronic component, so please do not storage and use, under a dewing state.

2 The product storage deadline is 12 months after delivery in unopened state. Please use within storage deadline. If you exceed storage deadline, please check the product characteristics etc, please use.

Handling of this document and other requests

Please refer to the " Site Guidance" on our website for the handling of information contained in this document. (<https://www.ndk.com/en/terms/>)