

Crystal Clock Oscillator

■ NZ2520SHB Data Sheet

Low Current Consumption Type (32.768 kHz)

Application

For Automotive navigation system, Automotive audio equipment and Camera

For car navigation, car audio, camera



RoHS Compliant
Directive 2011/65/EU
Directive (EU) 2015/863

Pb free

AEC
Q100/Q200

Features

- Supports a wide temperature range from -40 to +125 °C.
- Compact and light. Dimensions : 2.5 x 2.0 x 0.9 mm, weight : 0.02 g.
- Quick oscillation start up time is available compared to our Tuning Fork Crystal.
- Lead-free.
- Conforms to AEC-Q100/200.

1. Item : Crystal Clock Oscillator
 2. Type : NZ2520SHB
 3. Nominal Frequency : 32.768 kHz
 4. NDK Spec. No. : See Table1

5. Maximum Ratings

	Item	Ratings			Notes
		min	max	Units	
1	Supply Voltage	-0.3	+4.5	V	
2	Input Voltage	-0.3	$V_{CC} + 0.3$	V	
3	Output Current	-5	+5	mA	
4	Storage Temperature Range	-55	+125	°C	

6. Electrical Specifications

	Parameters	SYM	Electrical Spec.				Notes
			min	typ	max	Units	
1	Nominal Frequency	f_{nom}		32.768		kHz	
2	Supply Voltage	V_{CC}	+1.8 to +3.3			V	
3	Current Consumption (Operating)	I_{CC}	See Table.2			μA	at 25 °C, No load
4	Current Consumption (Stand-by)	I_{ST}			5	μA	at 25 °C
5	Output Level	-	CMOS				
6	Load Capacitance	C_L			15	pF	
7	Operating Temperature Range	T_{opr}	[-40 to +85] to [-40 to +125]			°C	Table.1
8	Overall Frequency Tolerance	$\Delta f/f_{nom}$	± 30 to ± 100			ppm	Table.1 *1
9	Long-term Frequency Stability	Δf_{lt}	-5		+5	ppm	at 25 °C, 1 year
10	Output Voltage	V_{OL}			$0.1 V_{CC}$	V	
		V_{OH}	$0.9 V_{CC}$			V	
11	Rise Time(t_r), Fall Time(t_f)	t_r/t_f			50	ns	$0.1 V_{CC}$ to $0.9 V_{CC}$
12	Symmetry	SYM	45		55	%	at $1/2 V_{CC}$
13	Start-up Time	t_{su}			30	ms	+1.8 V
					20	ms	+2.5 V ~ +3.3 V
14	Output Wave Form	-	Square wave				
15	Stand-by Function	#1 PAD input				# 3 PAD output	
		H level ($0.7 V_{CC}$ to V_{CC}) or open				Operating	
		L level ($0.3 V_{CC}$ max)				High impedance	

*1 Inclusive of Freq. tolerance (at 25 °C), frequency/temperature characteristics, frequency/voltage coefficient.

Table.1 NDK Spec. No. List

Overall Frequency Tolerance	Operating Temperature Range (°C)	Supply Voltage (V)			
		+1.8±0.18	+2.5±0.25	+3.0±0.3	+3.3±0.33
$\pm 100 \times 10^{-6}$	-40 to +125	NSC5135A	NSC5135B	NSC5135C	NSC5135D
$\pm 50 \times 10^{-6}$	-40 to +105	NSC5136A	NSC5136B	NSC5136C	NSC5136D
$\pm 50 \times 10^{-6}$	-40 to +85	NSC5137A	NSC5137B	NSC5137C	NSC5137D
$\pm 30 \times 10^{-6}$	-40 to +85	NSC5308A	NSC5308B	NSC5308C	NSC5308D

Table.2 Current Consumption (Operating)

Overall Frequency Tolerance [ppm]	Current Consumption (uA)	
	typ	max
$\pm 100 \times 10^{-6}$	10	18
$\pm 50 \times 10^{-6}$		
$\pm 30 \times 10^{-6}$	18	32

Output Voltage

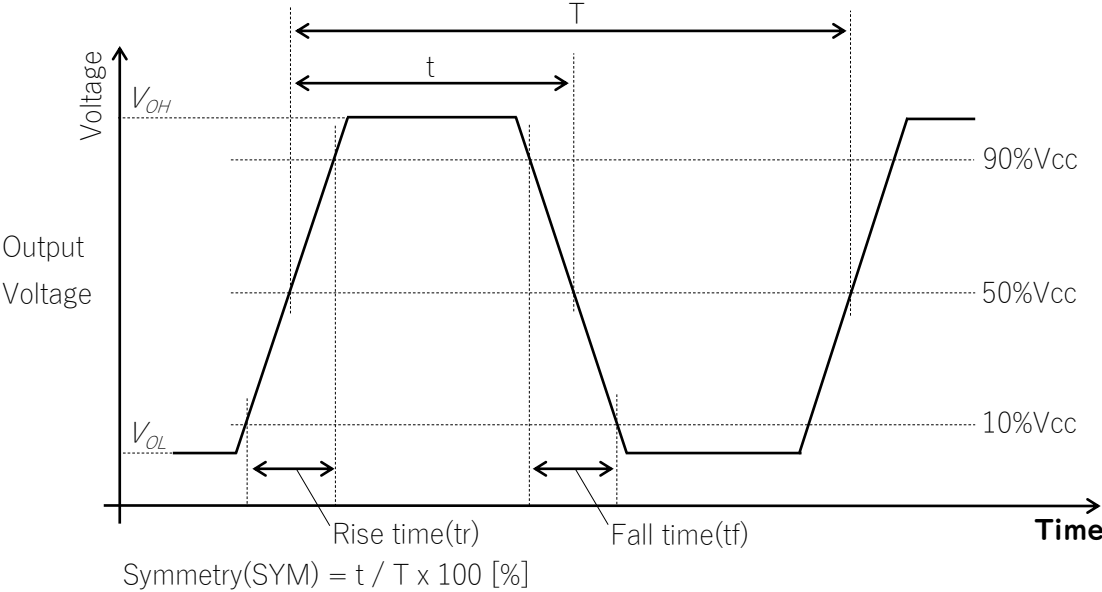

Start-up Time

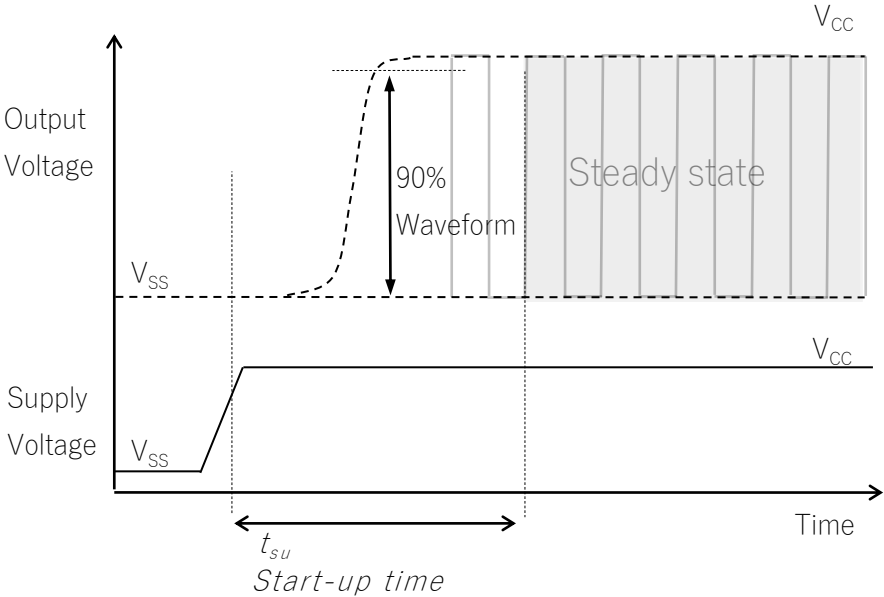

Measuring circuits

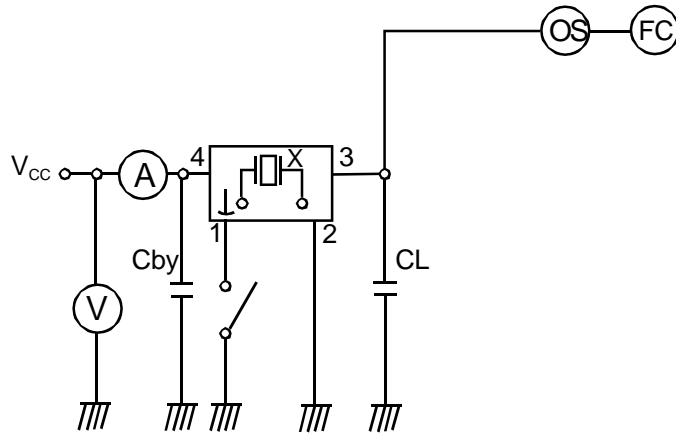

CL ; 15pF MAX including input capacity of oscilloscope
Cby ; Bypass capacitor (0.01uF)

7. Prohibited items

Example For Soldering Conditions (The below graph corresponds to Pb free solder)

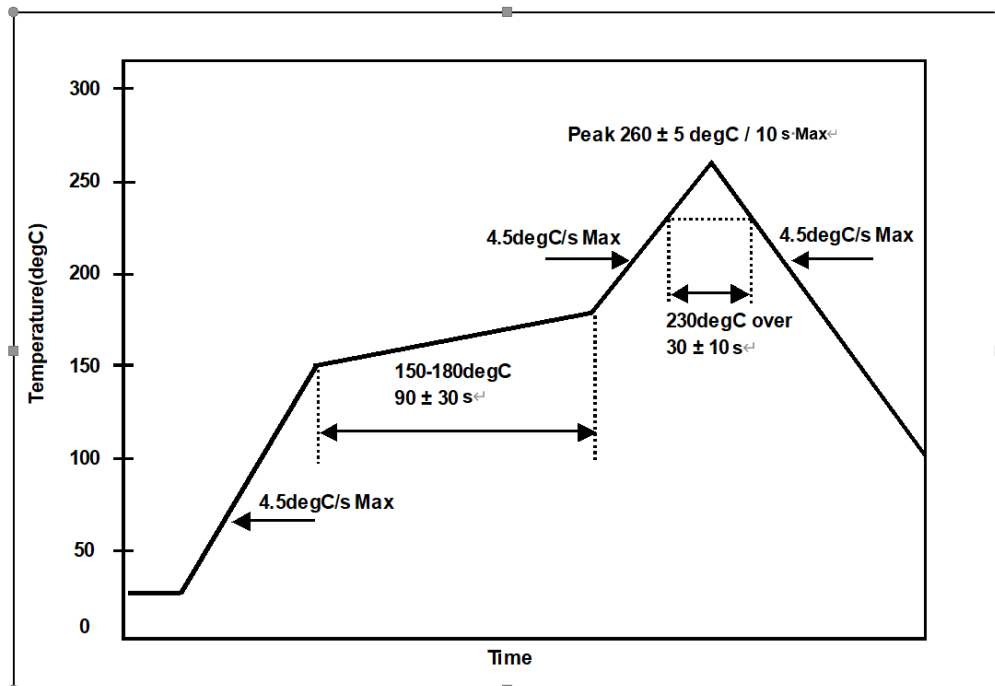

Be sure to use the product under the following conditions. Otherwise, the characteristics deterioration or destruction of the product may result.

(1) Reflow soldering heat resistance

Peak temperature: 265 °C, 10 s

Heating: 230 °C or higher, 40 s

Preheating: 150 °C to 180 °C, 120 s

Reflow passage times: 3 times

(2) Manual soldering heat resistance

Pressing a soldering iron of 350 °C on the terminal electrode for 3 s.

8. Electrostatic Discharge

MM: 200 V

HBM: 2000 V

CDM: 500 V

Dimension of External

Unit : mm

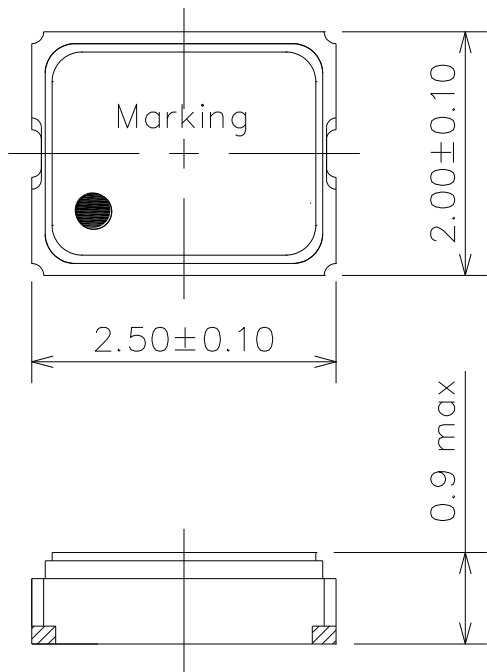

Terminal land connections

#1	STAND-BY
#2	GND
#3	OUTPUT
#4	V _{CC}

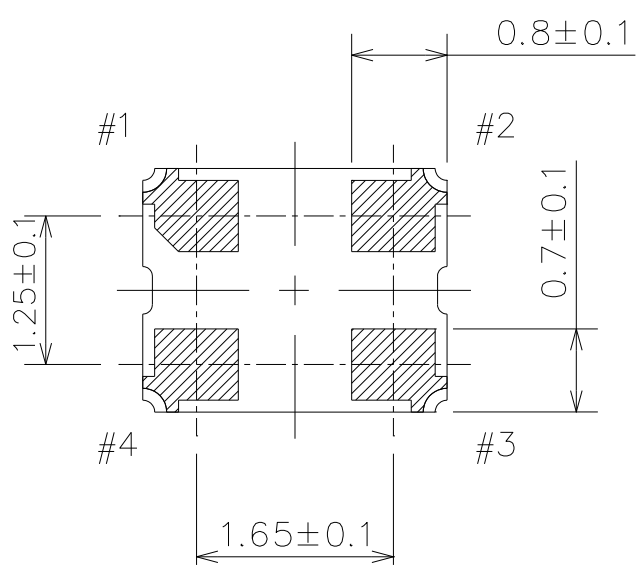
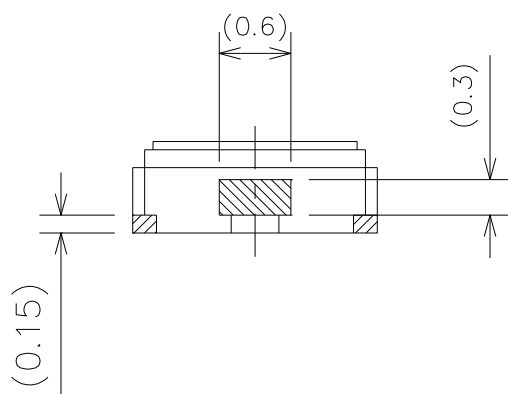

Land pattern (Recommended)

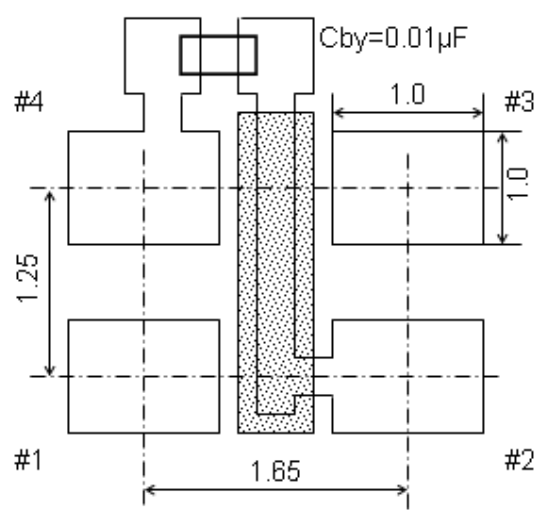

■ Taping and Reel Spec.

Unit : mm

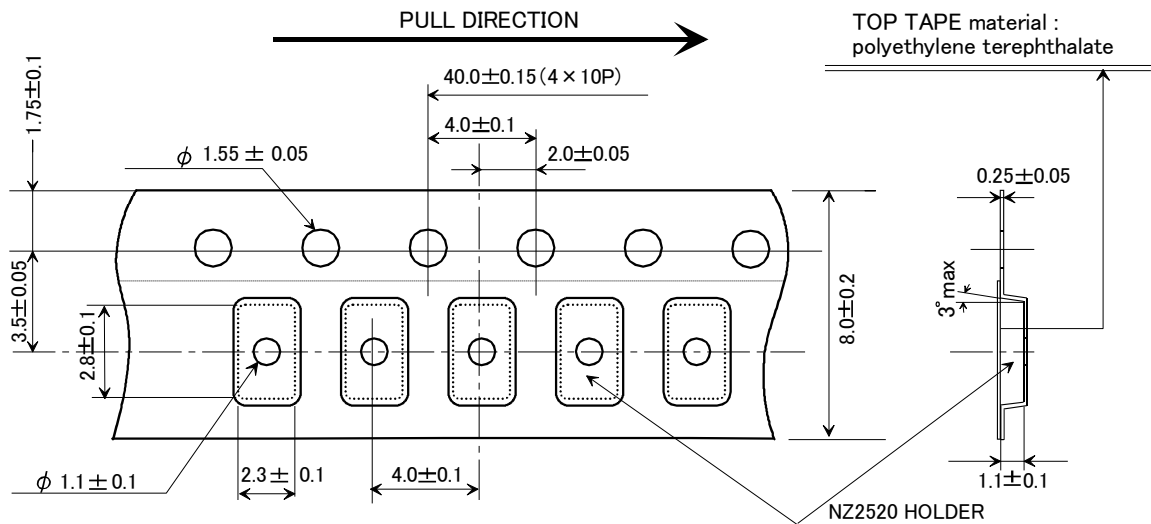

TAPING material: Conductive PS

DIRECTION OF UNIT →

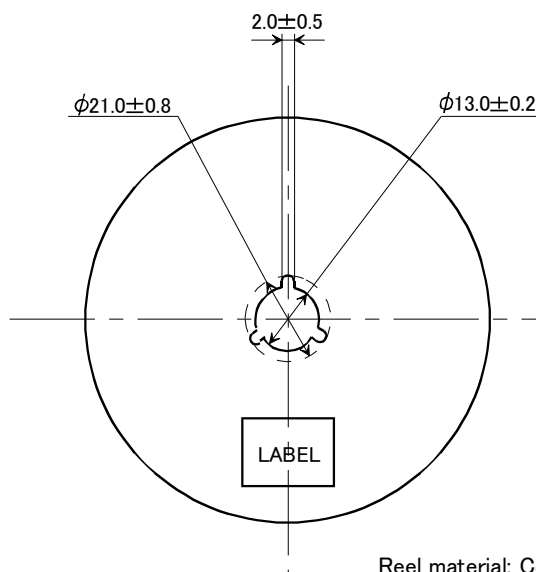

Reel material: Conductive PS

EIAJ standard reel

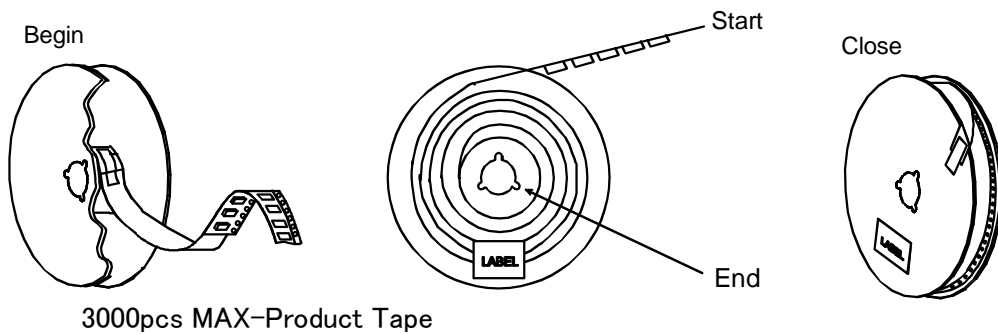

■ Marking

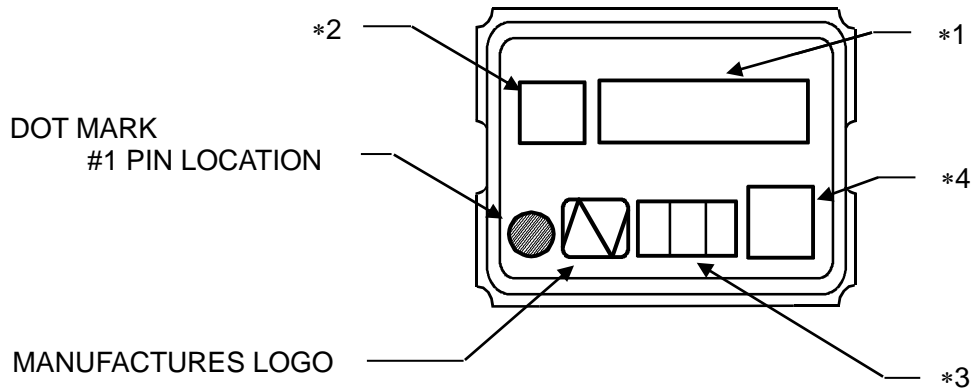

*1 [FREQUENCY]

*2 [MODEL MARK]
NZ2520SHB → H

*3 [WEEK CODE (Digit are three)]

*4 [Trace code]

Instruction Notice

1 Noise

When using this product, please insert a bypass capacitor between the power supply and GND.
(Closer to the product terminal is desirable.)

The bypass capacitor values shown in our specifications and drawings are for reference only.
(They are not guaranteed values.)

In actual use, please select the appropriate bypass capacitor value for your circuit.

NDK shall not be liable for any and all events resulting from or in connection with the use of this product in a manner that does not comply with the above instruction.

2 Resistance to dropping

The NZ2520S series is designed to be impactproof so that no damage occurs when dropped a height (75 cm) three times. However, if dropped from a desk etc., it is advisable to check their performance or contact us to check it.

3 Electrostatic protection

The NZ2520S series employ C-MOS ICs for the active element. Please use them in static-free environments.

4 Cleaning

Basically, the NZ2520S series are applicable for ultrasonic wave cleaning. However, in some case, during ultrasonic wave cleanings, internal design may get damage. Please check condition carefully beforehand.

5 Other

The NZ2520S series are C-MOS applied products. And careful handling (same as with C-MOS IC) are needed to avoid electrostatic problems.

Incorrect PAD connection is cause of trouble. Please make sure to connect correctly as below.

#2 terminal → GND

#4 terminal → V_{CC}

Notes On Use

- 1 Even if the appearance color etc. of the product differs by purchasing the component parts by more than two companies, there is no influence on the characteristics and reliability.
- 2 IN THE CASE OF THE FOLLOWING ITEMS, WE ARE NOT RESPONSIBLE FOR WARRANTY / COMPENSATION.
 - (1) WHEN PRODUCTS OF THIS SPECIFICATION ARE USED FOR EQUIPMENT RELATED TO HUMAN LIFE OR PROPERTY, IT IS THE RESPONSIBILITY OF THE CUSTOMER TO CONFIRM THE INFLUENCE ON THIS PRODUCT AND EQUIPMENT TO BE USED BEFOREHAND, CONDUCT NECESSARY SAFETY DESIGN (INCLUDING REDUNDANT DESIGN, MALFUNCTION PREVENTION DESIGN, etc.), PLEASE USE IT AFTER SECURING SUFFICIENT SAFETY OF EQUIPMENT.
 - 1.SAFETY-RELATED EQUIPMENT SUCH AS AUTOMOBILES, TRAINS, SHIPS, etc., OR EQUIPMENT DIRECTLY INVOLVED IN OPERATION
 - 2.AIRCRAFT EQUIPMENT
 - 3.SPACE EQUIPMENT
 - 4.MEDICAL EQUIPMENT
 - 5.MILITARY EQUIPMENT
 - 6.DISASTER PREVENTION / CRIME PREVENTION EQUIPMENT
 - 7.TRAFFIC LIGHT
 - 8.OTHER EQUIPMENT REQUIRING THE SAME PERFORMANCE AS THE ABOVE-MENTIONED EQUIPMENT
 - (2) IN CASES WHERE IT IS NOT INDICATED IN THE REQUESTED STANDARD AND IS USED UNDER CONDITIONS OF USE (INCLUDING CIRCUIT MARGIN etc.) THAT CAN NOT BE PREDICTED AT THE PRODUCTION STAGE.
 - (3) WHEN USING ULTRASONIC WELDING MACHINE.(THERE IS A POSSIBILITY THAT THE CHARACTERISTIC DEGRADATION IS CAUSED BY THE RESONANCE PHENOMENON OF THE PIEZOELECTRIC MATERIAL.(EXAMPLE;CRYSTAL PIECE)) WE WILL NOT TAKE ANY RESPONSIBILITY FOR THE INFLUENCE OF THE CUSTOMERS' PROCESS.
SO, PLEASE SUFFICIENTLY EVALUATE AT A SAMPLE STEP WHEN YOU USE ULTRASONIC WELDING MACHINE.

- (4) USING RESIN MOLD MAY AFFECT THE PRODUCT CHARACTERISTIC.
PLEASE MAKE SURE TO TELL OUR SALES CONTACT WHEN YOU USE RESIN MOLD. WE WILL PERFORM INDIVIDUAL CORRESPONDENCE ABOUT A DELIVERY SPECIFICATION AND A EVALUATION METHOD.
IN ADDITION, IF YOU USE RESIN MOLD WITHOUT CONTACTING US, AND CAUSES DAMAGES AGAINST A CUSTOMER OR A THIRD PARTY, WE WILL NOT BE LIABLE FOR THE DAMAGES AND OTHER RESPONSIBILITIES BECAUSE WE CONSIDER IT IS UNDER ELF-RESPONSIBILITY USING RESIN MOLD.
WE WILL NOT TAKE ANY RESPONSIBILITY FOR THE INFLUENCE OF THE CUSTOMERS' PROCESS. PLEASE EFFICIENTLY EVALUATE AT A SAMPLE STEP WHEN YOU USE RESIN MOLD.
- (5) WHEN PERFORMING IMPROPER HANDLING THAT EXCEEDS THE GUARANTEED RANGE.
- 3 This product can not be used for equipment related to the safety of automobiles or equipment directly involved in operation.(example: air bag, TPMS, engine control, steering control, brake control etc.)

Notes on storage

- 1 When storing the product in high temperature and high humidity condition for a long time, product characteristics (solderability etc.) and packaging condition may be deteriorated. Please store product at temperature + 5 °C to + 35 °C, humidity 85 % RH or less. The product is an electronic component, so please do not storage and use, under a dewing state.
- 2 The product storage deadline is 12 months after delivery in unopened state. Please use within storage deadline. If you exceed storage deadline, please check the product characteristics etc, please use.

Handling of this document and other requests

Please refer to the " Site Guidance" on our website for the handling of information contained in this document. (<https://www.ndk.com/en/terms/>)