

Crystal Clock Oscillator

■ NZ2520SEB Data Sheet High-precision Type

Application

For car navigation, car audio, camera
For Digital camera, SLR camera, etc.



RoHS Compliant
Directive 2011/65/EU
Directive (EU) 2015/863

Pb free

AEC
Q100/Q200

Features

- Overall Frequency Tolerance Max. $\pm 25 \times 10^{-6}$ at -40 to $+85^{\circ}\text{C}$
- Compact and light. Dimensions: 2.5 x 2.0 x 0.9 mm, weight: 0.02 g.
- Taped units enable automatic mounting IR Reflow (lead free) is possible.
- Conforms to AEC-Q100/200
- Lead-free.

1. Item : Crystal Clock Oscillator
 2. Type : NZ2520SEB
 3. Nominal Frequency : 1.5 to 32 MHz
 4. NDK Spec. No. : See Table1

5. Maximum Ratings

	Item	Ratings			Notes
		min	max	Units	
1	Supply Voltage	-0.3	+4.5	V	
2	Input Voltage	-0.3	$V_{CC} + 0.3$	V	
3	Output Current	-20	+20	mA	
4	Storage Temperature Range	-55	+125	°C	

6. Electrical Specifications

	Parameters	SYM	Electrical Spec.				Notes
			min	typ	max	Units	
1	Nominal Frequency	f_{nom}	1.5		32	MHz	
2	Supply Voltage	V_{CC}	+1.8 to +3.3			V	*1
3	Current Consumption (Operating)	I_{CC}	See Table.2			mA	at 25 °C
4	Current Consumption (Stand-by)	I_{ST}			10	μA	at 25 °C
5	Output Level	-	CMOS				
6	Load Capacitance	C_L			15	pF	
7	Operating Temperature Range	T_{opr}	[-10 to +60] to [-40 to +85]			°C	Table 1
8	Overall Frequency Tolerance	$\Delta f/f_{nom}$	± 12 to ± 25			ppm	Table 1 *1
9	Output Voltage	V_{OL}			0.1 V_{CC}	V	
		V_{OH}	0.9 V_{CC}			V	
10	Rise Time(t_r), Fall Time(t_f)	t_r/t_f			5	ns	0.1 V_{CC} to 0.9 V_{CC}
11	Symmetry	SYM	45		55	%	at 1/2 V_{CC}
12	Start-up Time	t_{su}			4	ms	
13	Output Wave Form	-	Square wave				
14	Stand-by Function	#1 PAD input				# 3 PAD output	
		H level (0.7 V_{CC} to V_{CC}) or open				Operating	
		L level (0.3 V_{CC} max)				High impedance	

*1 Inclusive of Freq. tolerance (at 25 °C), frequency/temperature characteristics, frequency/voltage coefficient.

Table.1 NDK Spec. No. List

Overall Frequency Tolerance	Operating Temperature Range (°C)	Supply Voltage (V)			
		+1.8±0.18	+2.5±0.25	+3.0±0.3	+3.3±0.33
$\pm 25 \times 10^{-6}$	-40 ~ +85	NSC5281A	NSC5281B	NSC5281C	NSC5281D
$\pm 20 \times 10^{-6}$	-30 ~ +85	NSC5282A	NSC5282B	NSC5282C	NSC5282D
$\pm 15 \times 10^{-6}$	-20 ~ +70	NSC5283A	NSC5283B	NSC5283C	NSC5283D
$\pm 12 \times 10^{-6}$	-10 ~ +60	NSC5284A	NSC5284B	NSC5284C	NSC5284D

Table.2 Current Consumption (Operating)

Nominal Frequency [MHz]	Current Consumption (mA)			
	$1.5 \leq F < 10$	$10 \leq F < 20$	$20 \leq F < 30$	$30 \leq F \leq 32$
1.8 V	2.5 MAX	3.5 MAX	4.0 MAX	4.5 MAX
2.5 V	3.0 MAX	4.0 MAX	4.5 MAX	5.0 MAX
3.0 V	3.5 MAX	4.5 MAX	5.0 MAX	5.5 MAX
3.3 V	3.5 MAX	4.5 MAX	5.0 MAX	5.5 MAX

Table.3 Supported Frequency List

Nominal Frequency [MHz]						
8 MHz						
12 MHz						
12.288 MHz						
15.625 MHz						
16 MHz						
24 MHz						
25 MHz						
26 MHz						
32 MHz						

Frequencies not listed in the list are also available, so please contact us if you have any request.

Output Voltage

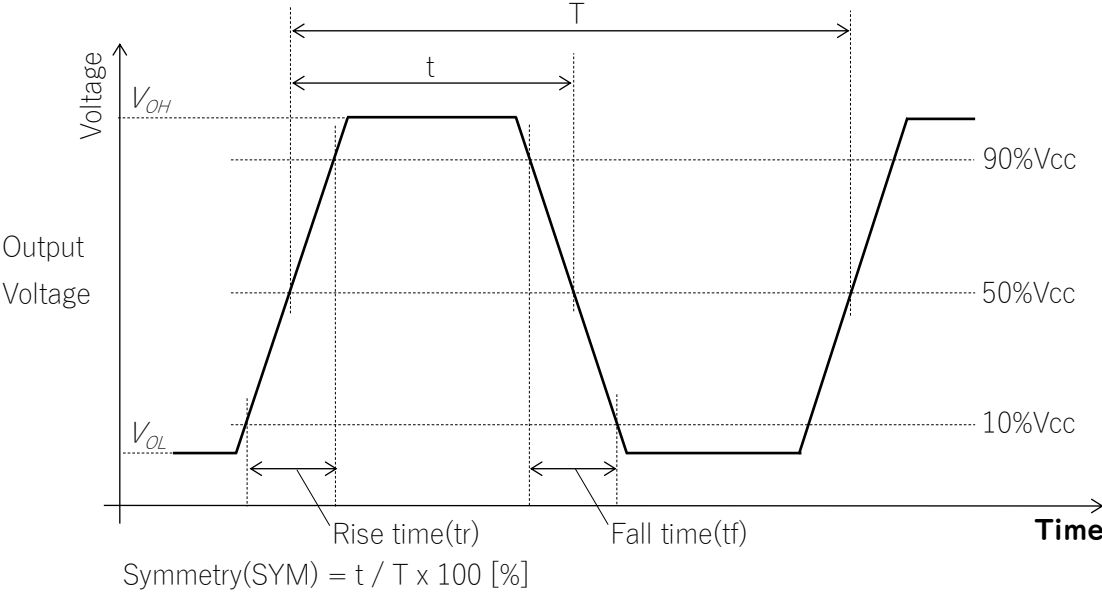

Start-up Time

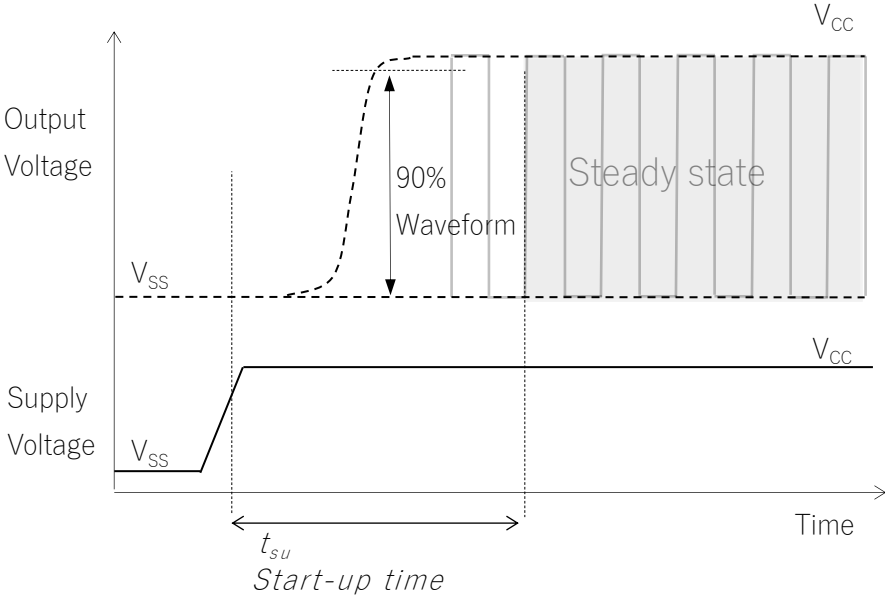

Measuring circuits

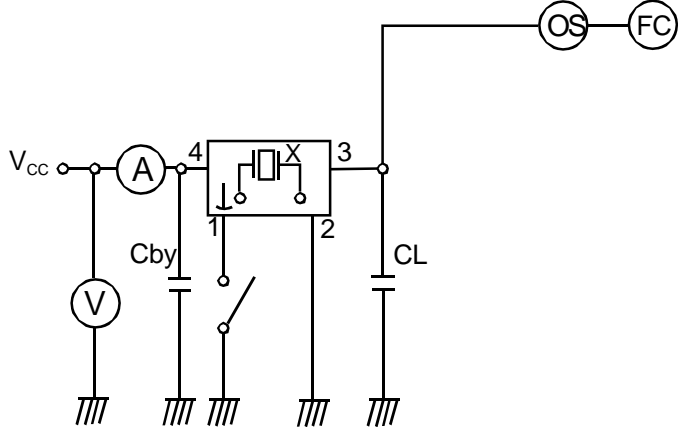

CL ; 15pF MAX including input capacity of oscilloscope
Cby ; Bypass capacitor (0.01uF)

7. Prohibited items

Example For Soldering Conditions (The below graph corresponds to Pb free solder)

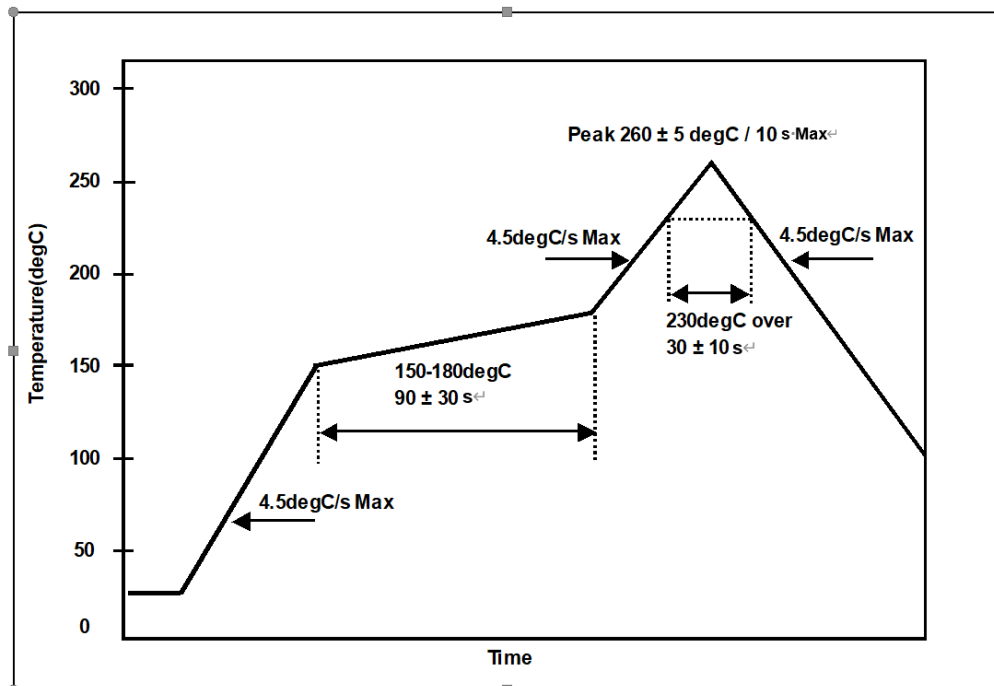

Be sure to use the product under the following conditions. Otherwise, the characteristics deterioration or destruction of the product may result.

- (1) Reflow soldering heat resistance
 - Peak temperature: 265 °C, 10 s
 - Heating: 230 °C or higher, 40 s
 - Preheating: 150 °C to 180 °C, 120 s
 - Reflow passage times: 3 times
- (2) Manual soldering heat resistance
 - Pressing a soldering iron of 350 °C on the terminal electrode for 3 s.

8. Electrostatic Discharge

MM: 200 V
HBM: 2000 V
CDM: 500 V

Dimension of External

Unit : mm

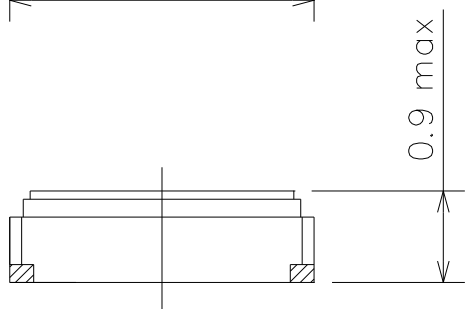
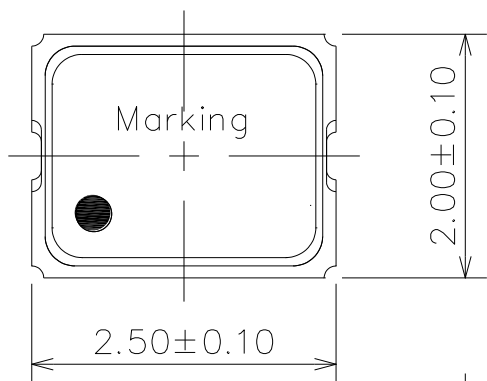

Terminal land connections

#1	STAND-BY
#2	GND
#3	OUTPUT
#4	V _{CC}

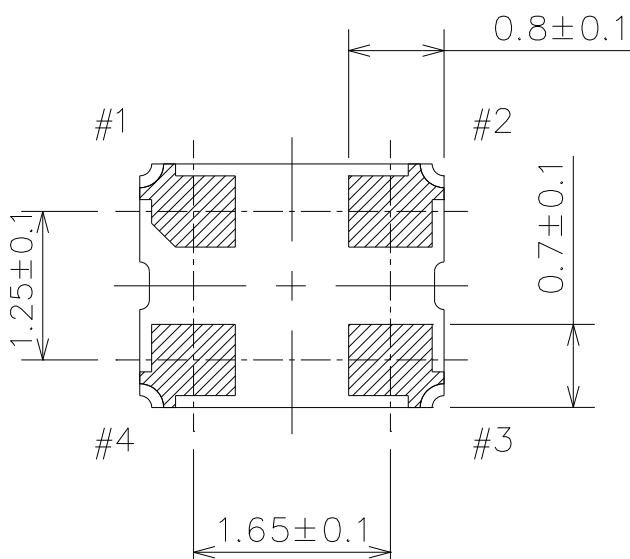
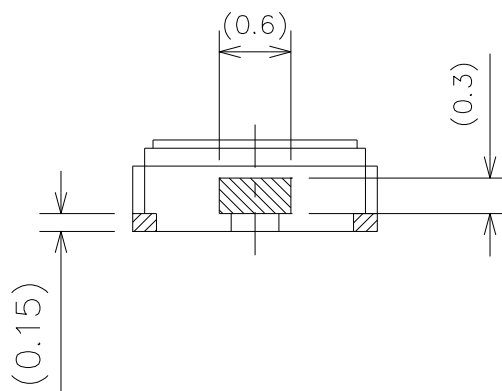

Land pattern (Recommended)

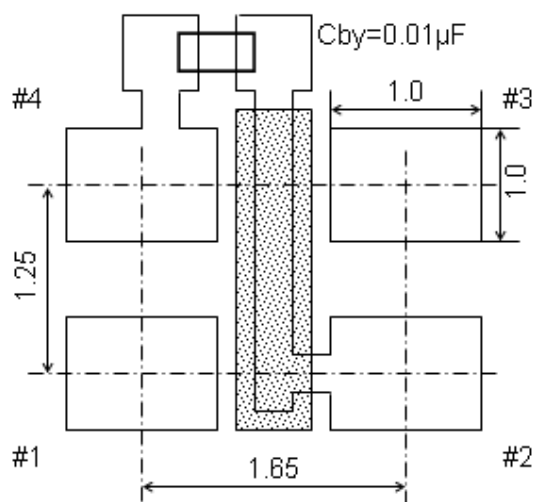

■ Taping and Reel Spec.

Unit : mm

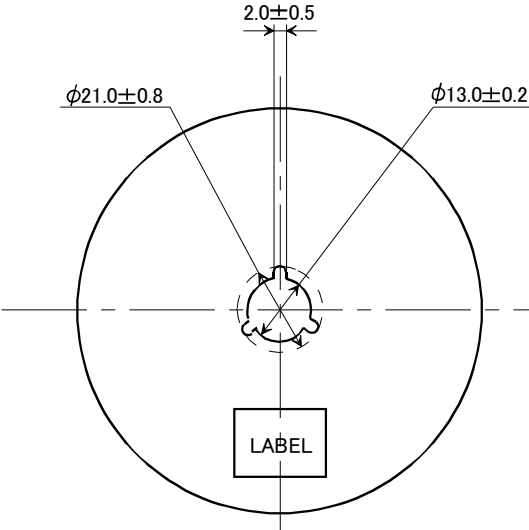
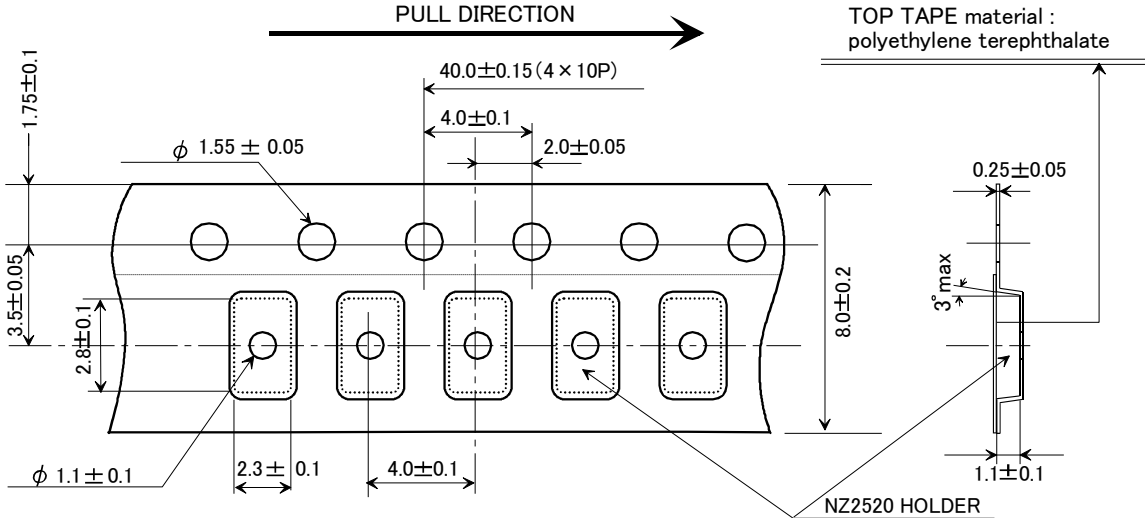

Reel material: Conductive PS
EIAJ standard reel

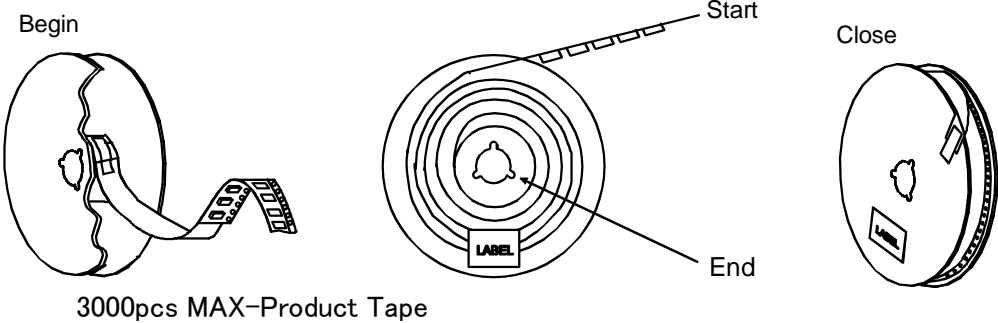
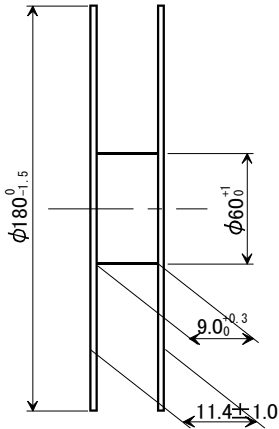

3000pcs MAX-Product Tape

■ Marking

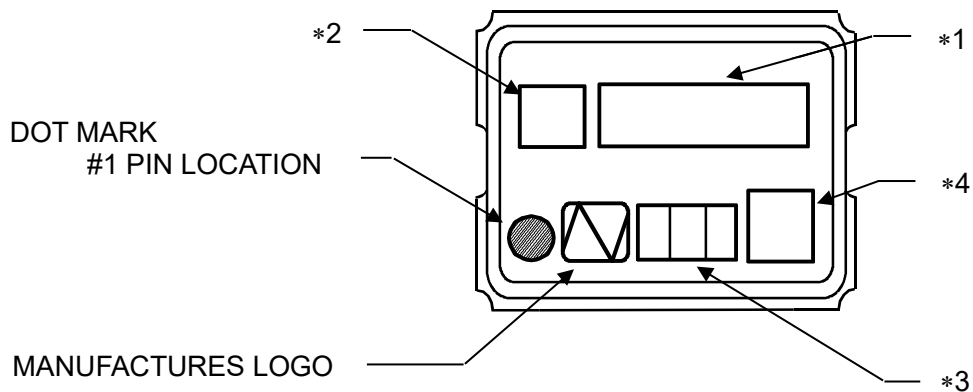

*1 [FREQUENCY]

*2 [MODEL MARK]
NZ2520SEB → E

*3 [WEEK CODE (Digit are three)]

*4 [Trace code]

Instruction Notice

1 Noise

When using this product, please insert a bypass capacitor between the power supply and GND.
(Closer to the product terminal is desirable.)

The bypass capacitor values shown in our specifications and drawings are for reference only.
(They are not guaranteed values.)

In actual use, please select the appropriate bypass capacitor value for your circuit.

NDK shall not be liable for any and all events resulting from or in connection with the use of this product in a manner that does not comply with the above instruction.

2 Resistance to dropping

The NZ2520S series is designed to be impactproof so that no damage occurs when dropped a height (75 cm) three times. However, if dropped from a desk etc., it is advisable to check their performance or contact us to check it.

3 Electrostatic protection

The NZ2520S series employ C-MOS ICs for the active element. Please use them in static-free environments.

4 High temperature

Normal operation cannot be guaranteed for the NZ2520S series at +125 °C (for 24 h). Be sure that the units are kept within the specified temperature range.

5 Cleaning

Basically, the NZ2520S series are applicable for ultrasonic wave cleaning. However, in some case, during ultrasonic wave cleanings, internal design may get damage. Please check condition carefully beforehand.

6 Other

The NZ2520S series are C-MOS applied products. And careful handling (same as with C-MOS IC) are needed to avoid electrostatic problems.

Incorrect PAD connection is cause of trouble. Please make sure to connect correctly as below.

#2 terminal → GND

#4 terminal → V_{CC}

Notes On Use

- 1 Even if the appearance color etc. of the product differs by purchasing the component parts by more than two companies, there is no influence on the characteristics and reliability.
- 2 IN THE CASE OF THE FOLLOWING ITEMS, WE ARE NOT RESPONSIBLE FOR WARRANTY / COMPENSATION.
 - (1) WHEN PRODUCTS OF THIS SPECIFICATION ARE USED FOR EQUIPMENT RELATED TO HUMAN LIFE OR PROPERTY, IT IS THE RESPONSIBILITY OF THE CUSTOMER TO CONFIRM THE INFLUENCE ON THIS PRODUCT AND EQUIPMENT TO BE USED BEFOREHAND, CONDUCT NECESSARY SAFETY DESIGN (INCLUDING REDUNDANT DESIGN, MALFUNCTION PREVENTION DESIGN, etc.), PLEASE USE IT AFTER SECURING SUFFICIENT SAFETY OF EQUIPMENT.
 - 1.SAFETY-RELATED EQUIPMENT SUCH AS AUTOMOBILES, TRAINS, SHIPS, etc., OR EQUIPMENT DIRECTLY INVOLVED IN OPERATION
 - 2.AIRCRAFT EQUIPMENT
 - 3.SPACE EQUIPMENT
 - 4.MEDICAL EQUIPMENT
 - 5.MILITARY EQUIPMENT
 - 6.DISASTER PREVENTION / CRIME PREVENTION EQUIPMENT
 - 7.TRAFFIC LIGHT
 - 8.OTHER EQUIPMENT REQUIRING THE SAME PERFORMANCE AS THE ABOVE-MENTIONED EQUIPMENT
 - (2) IN CASES WHERE IT IS NOT INDICATED IN THE REQUESTED STANDARD AND IS USED UNDER CONDITIONS OF USE (INCLUDING CIRCUIT MARGIN etc.) THAT CAN NOT BE PREDICTED AT THE PRODUCTION STAGE.

- (3) WHEN USING ULTRASONIC WELDING MACHINE.(THERE IS A POSSIBILITY THAT THE CHARACTERISTIC DEGRADATION IS CAUSED BY THE RESONANCE PHENOMENON OF THE PIEZOELECTORIC MATERIAL.(EXAMPLE;CRYSTAL PIECE))
WE WILL NOT TAKE ANY RESPONSIBILITY FOR THE INFLUENCE OF THE CUSTOMERS' PROCESS.
SO, PLEASE SUFFICIENTLY EVALUATE AT A SAMPLE STEP WHEN YOU USE ULTRASONIC WELDING MACHINE.
 - (4) USING RESIN MOLD MAY AFFECT THE PRODUCT CHARACTERISTIC.
PLEASE MAKE SURE TO TELL OUR SALES CONTACT WHEN YOU USE RESIN MOLD. WE WILL PERFORM INDIVIDUAL CORRESPONDENCE ABOUT A DELIVERY SPECIFICATION AND A EVALUATION METHOD.
IN ADDITION, IF YOU USE RESIN MOLD WITHOUT CONTACTING US, AND CAUSES DAMAGES AGAINST A CUSTOMER OR A THIRD PARTY, WE WILL NOT BE LIABLE FOR THE DAMAGES AND OTHER RESPONSIBILITIES BECAUSE WE CONSIDER IT IS UNDER ELF-RESPONSIBILITY USING RESIN MOLD.
WE WILL NOT TAKE ANY RESPONSIBILITY FOR THE INFLUENCE OF THE CUSTOMERS' PROCESS. PLEASE EFFICIENTLY EVALUATE AT A SAMPLE STEP WHEN YOU USE RESIN MOLD.
 - (5) WHEN PERFORMING IMPROPER HANDLING THAT EXCEEDS THE GUARANTEED RANGE.
- 3 This product cannot be used for equipment related to the safety of automobiles or equipment directly involved in operation.(example: air bag, TPMS, engine control, steering control, brake control etc.)

Notes on storage

- 1 When storing the product in high temperature and high humidity condition for a long time, product characteristics (solderability etc.) and packaging condition may be deteriorated. Please store product at temperature + 5 °C to + 35 °C, humidity 85 % RH or less. The product is an electronic component, so please do not storage and use, under a dewing state.
- 2 The product storage deadline is 12 months after delivery in unopened state. Please use within storage deadline. If you exceed storage deadline, please check the product characteristics etc, please use.

Handling of this document and other requests

Please refer to the " Site Guidance" on our website for the handling of information contained in this document. (<https://www.ndk.com/en/terms/>)