



Oven Controlled Crystal Oscillator (OCXO)

■ NH7050SA Data Sheet

Main Application

- Base stations for system mobile communications (5G RU, AAS, 4G RRH)
- IEEE Synchronous Ethernet clock (SyncE)
- Optical transmission systems Stratum 3
- GNSS-DO
- Timing and synchronous measuring equipment

Features

- Compact, with a low height.
- Supports high temperature range. (+95 °C)
- Hermetic sealing package for excellent environmental-proof performance.
- Low power Consumption : 0.6 W or less. (at +25 °C)
- Dimension : 7.0 × 5.0 × 3.3 mm

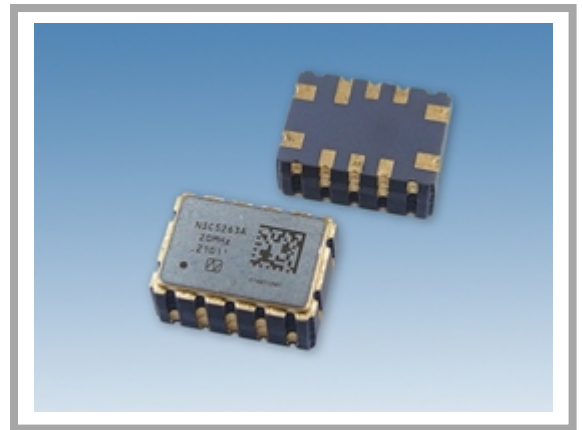

RoHS Compliant

Directive 2011/65/EU
Directive (EU) 2015/863

1. Item : Oven Controlled Crystal Oscillator

2. Type : NH7050SA

3. Nominal Frequency: 10, 20, 30.72, 38.88 MHz

4. NDK Spec No. : NSC5263[A, B]

Please refer to Table 6 Electrical characteristics as the alphabet at the end changes depending on the electrical characteristics.

5. Rating

Parameters	Sym.	Spec.				Conditions
		Min.	Typ.	Max.	Units	
5.1 Nominal Frequency	f_{nom}	10, 20, 30.72, 38.88				MHz
5.2 Supply Voltage	V_{CC}	+3.135	+3.3	+3.465	V	
5.3 Load	C_L	-	15	-	pF	
5.4 Operating Temperature Range	T_{opr}	-40	-	+95	°C	
5.5 Storage Temperature Range	T_{str}	-40	-	+95	°C	

6. Electrical Specifications

Unless otherwise specified, meaning condition. $T = +25\text{ °C}$, $V_{CC} = +3.3\text{ V}$, $C_L = 15\text{ pF}$

Parameters	Sym.	Spec.				Conditions
		Min.	Typ.	Max.	Units	
6.1 Power Consumption						
6.1.1 During Warm-up	P_{CC}	-	1.0	1.5	W	
6.1.2 Steady State	P_{CC}	-	0.4	0.6	W	$T = +25\text{ °C}$
6.2 Frequency Stability						
6.2.1 Frequency Tolerance	$\Delta f/f_{nom}$	-500	-	+500	ppb	(*1)
6.2.2 Frequency/ Temperature Characteristics	$\Delta f/f$	-20	-	+20	ppb	NSC5263A (*2)
		-50	-	+50	ppb	NSC5263B (*2)
6.2.3 Frequency/ Temperature Slope	-	-0.5	-	+0.5	ppb/°C	5th order approximation NSC5263A
		-1	-	+1	ppb/°C	5th order approximation NSC5263B
6.2.4 Frequency/Voltage Coefficient	$\Delta f/f$	-10	±5	+10	ppb	$V_{CC} = +3.3\text{ V} \pm 5\%$ (*3)
6.2.5 Long-term Frequency stability	$\Delta f/f$	-3	-	+3	ppb	at 20 MHz, 1 day (*4)
		-300	-	+300	ppb	at 20 MHz, 1 year (*4)
6.2.6 Stabilization Time	-	-	10	60	sec	(*5)
6.3 Output Characteristics						
6.3.1 Waveform	-	LVCMOS (Square wave)				
6.3.2 Output Voltage						
High Level Output Voltage	V_{OH}	+3.0	-	-	V	
Low Level Output Voltage	V_{OL}	-	-	+0.3	V	
6.3.3 Symmetry	-	45	-	55	%	at $(V_{OH} + V_{OL})/2$

Parameters		Sym.	Spec.				Conditions
			Min.	Typ.	Max.	Units	
6.4	Phase Noise at 10 MHz	L(f)	-	-83	-	dBc/Hz	1 Hz offset
			-	-120	-	dBc/Hz	10 Hz offset
			-	-142	-	dBc/Hz	100 Hz offset
			-	-153	-	dBc/Hz	1 kHz offset
			-	-157	-	dBc/Hz	10 kHz offset
			-	-160	-	dBc/Hz	100 kHz offset

(*1) $\Delta f/f_{nom}$: Frequency shift from nominal frequency.

(*2) $\Delta f/f$: Frequency shift from the reference frequency which is $(F_{max} + F_{min})/2$ within $-40 \sim +95 \text{ }^\circ\text{C}$,
 $V_{CC} = +3.3 \text{ V}$, $C_L = 15 \text{ pF}$

(*3) $\Delta f/f$: Frequency shift from the reference frequency. $T = +25 \text{ }^\circ\text{C}$, $V_{CC} = +3.3 \text{ V}$, $C_L = 15 \text{ pF}$

(*4) Based on frequency after 30 days operation.

(*5) Within $\pm 25 \text{ ppb}$, based on frequency after 60 minutes. $T = +25 \text{ }^\circ\text{C}$.

(*6) Typ. value is for reference only.

Stabilization Time

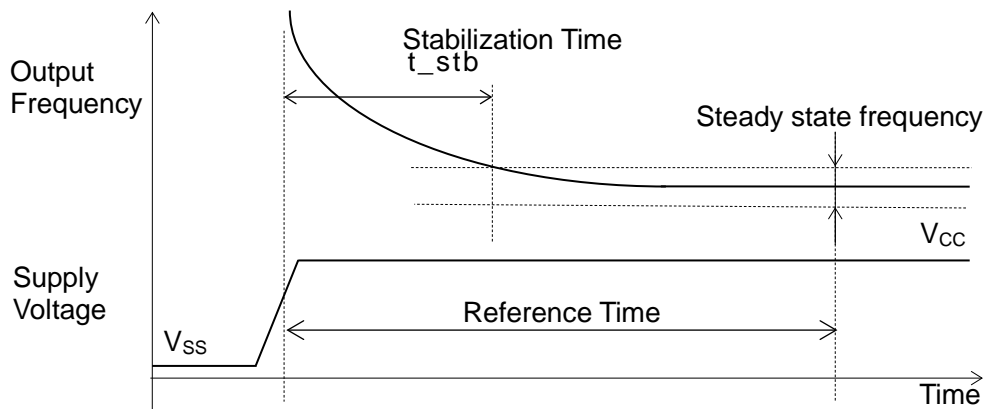

Waveform

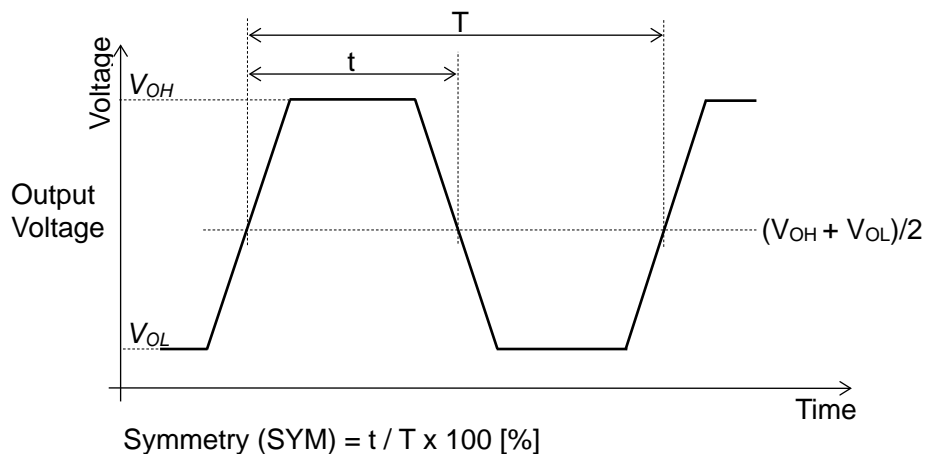

7. Marking

7.1. NDK Spec. No.

7.2. Nominal Frequency

7.3. NDK symbol mark

7.4. Manufacture Date

7.5. Dot mark

It might be printed NDK management code to the oscillator bottom by the laser trimming.

8. Moisture Sensitive Level : Level 1

9. Recommended Measurement Circuit

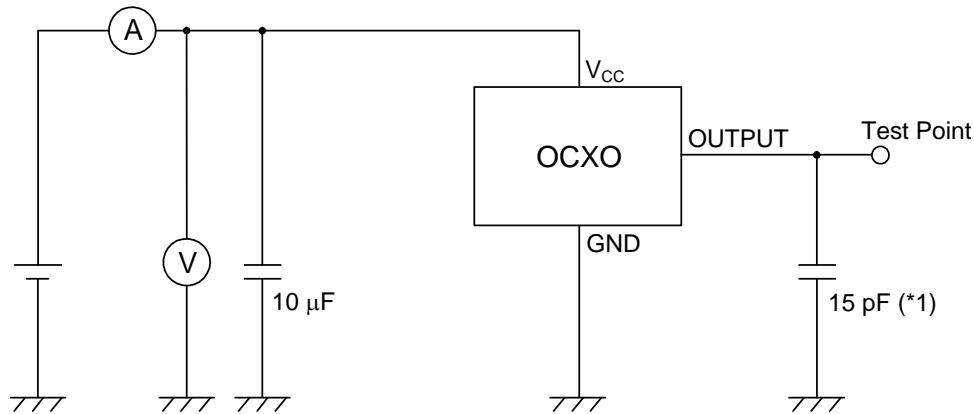

(*1) Including capacitance of measurement jig and probe

10. Mount condition

Be sure to use the product under the following conditions. Otherwise, the characteristics deterioration or destruction of the product may result.

[Reflow soldering, Flow soldering heat resistance]

Preheating: 150 °C to 200 °C, 60 to 120 s

Ramp up rate: Max. 3 °C/s

Heating: 217 °C or higher, 30 to 90 s

Peak temperature: 245 °C, +0/-5 °C

Time within 5 °C of Peak temperature: < 30 s

Reflow passage times: twice

In reflowing, the turning over of mounted boards shall be forbidden.

[Hand soldering heat resistance]

Press a soldering iron of 350 °C on the lead electrode for five seconds (twice).

11. ESD

•Machine Model (MM)

Max. +/-200 V (Standards JESD22-A115)

•Human Body Model (HBM)

Max. +/-2000 V (Standards JESD22-A114)

•Charged Device Model (CDM)

Max. +/-500 V (Standards JESD22-C101)

12. Prohibited items

OCXO is designed to keep the performance by continuous operation. Therefore, please avoid use of OCXO which repeats ON-OFF of a power supply frequently.

■ Dimension of External

Unit : mm

Tolerance : ± 0.2

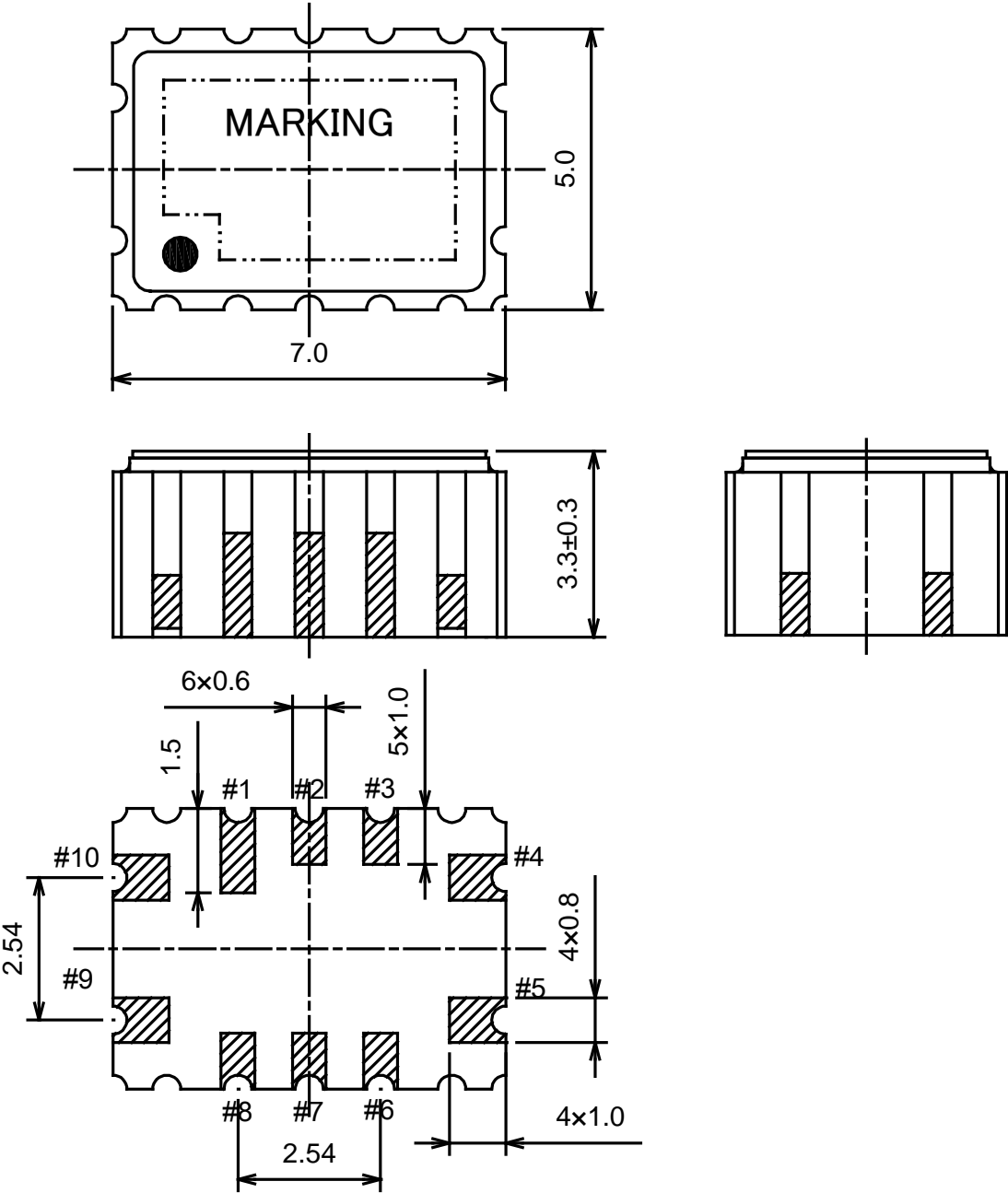

■ Terminal Function

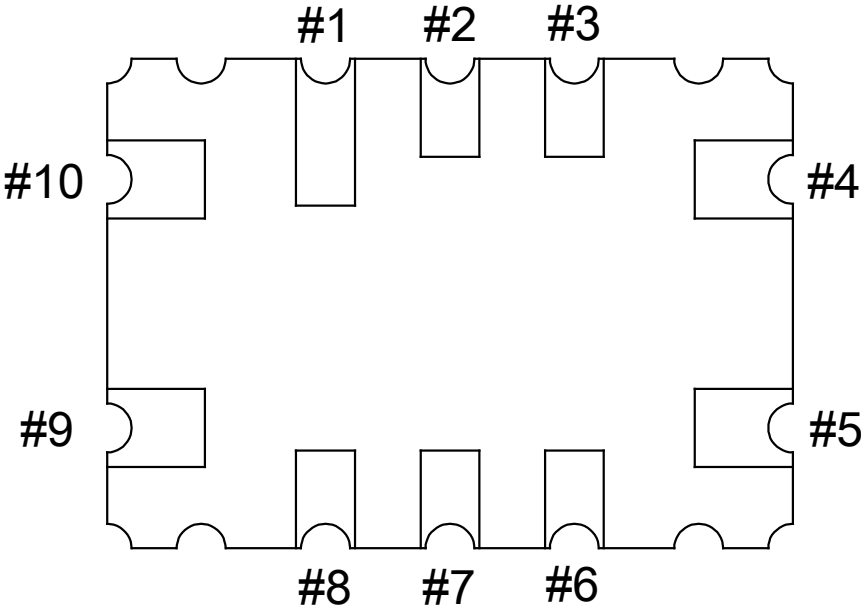

Pin connections	
#1	DNC (Don't connect)
#2	DNC (Don't connect)
#3	DNC (Don't connect)
#4	GND
#5	OUTPUT
#6	DNC (Don't connect)
#7	DNC (Don't connect)
#8	DNC (Don't connect)
#9	V _{CC}
#10	DNC (Don't connect)

■ Recommended Land Pattern

Unit : mm

Tolerance : ±0.1

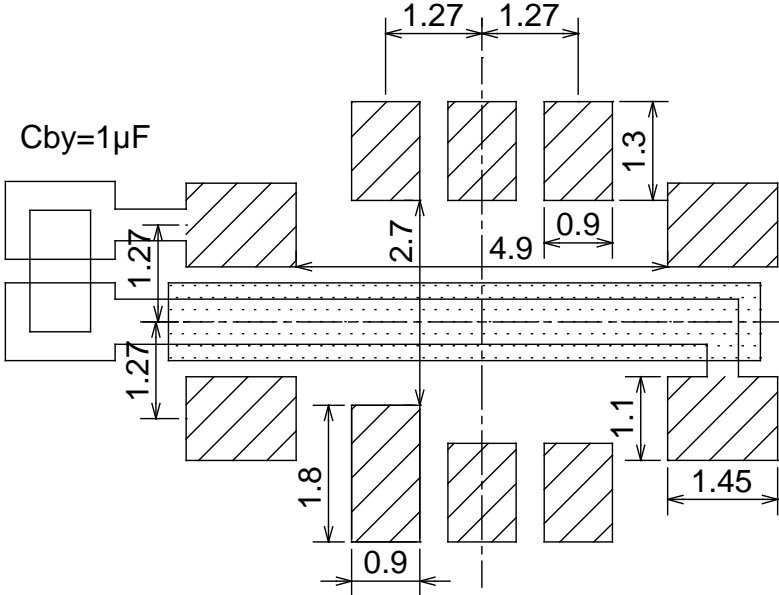

Note) Please connect the bypass capacitor (for example: 1 uF) of a power supply near the V_{CC} terminal.

■ Taping and Reel Spec.

Storage quantity : MAX 1000 PCS

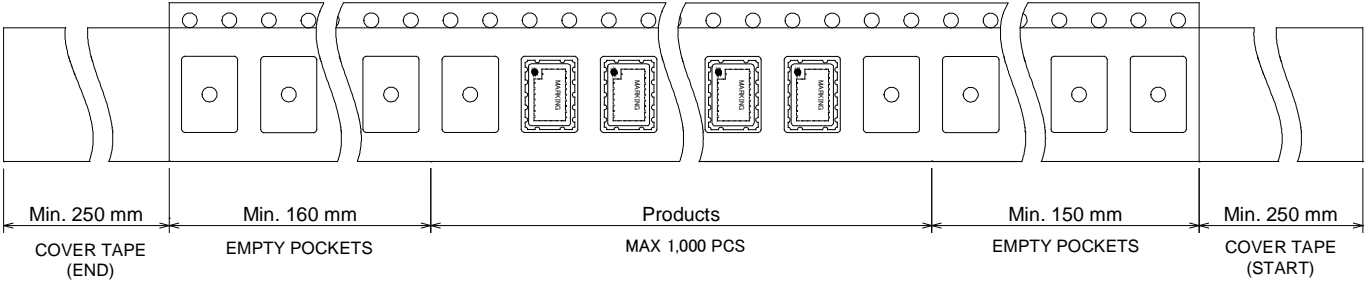
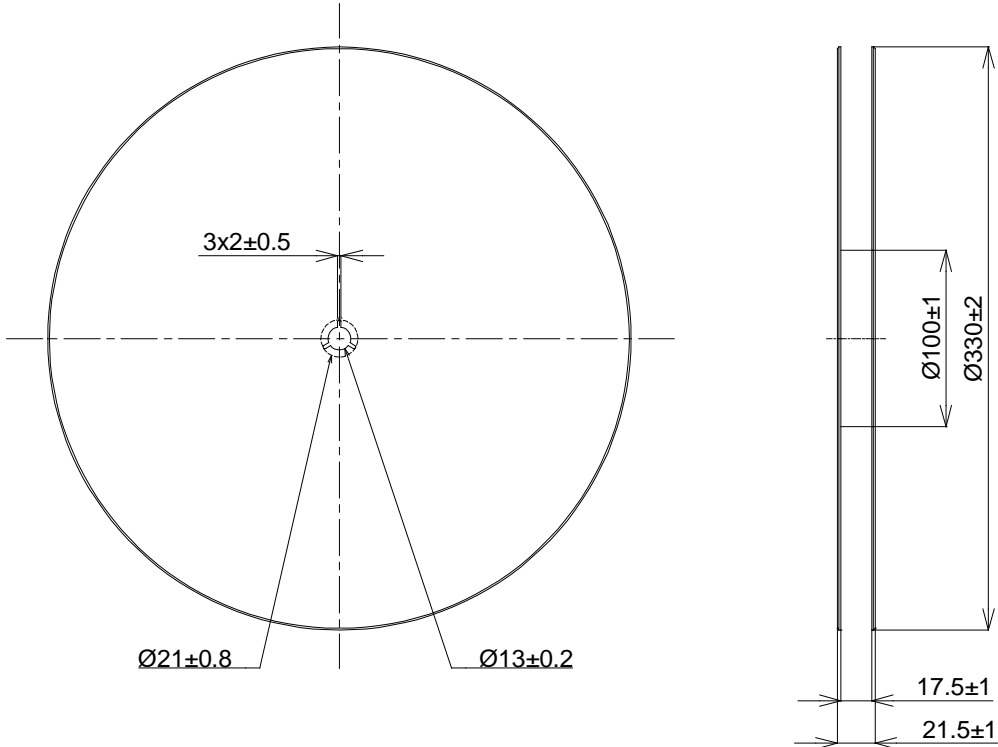

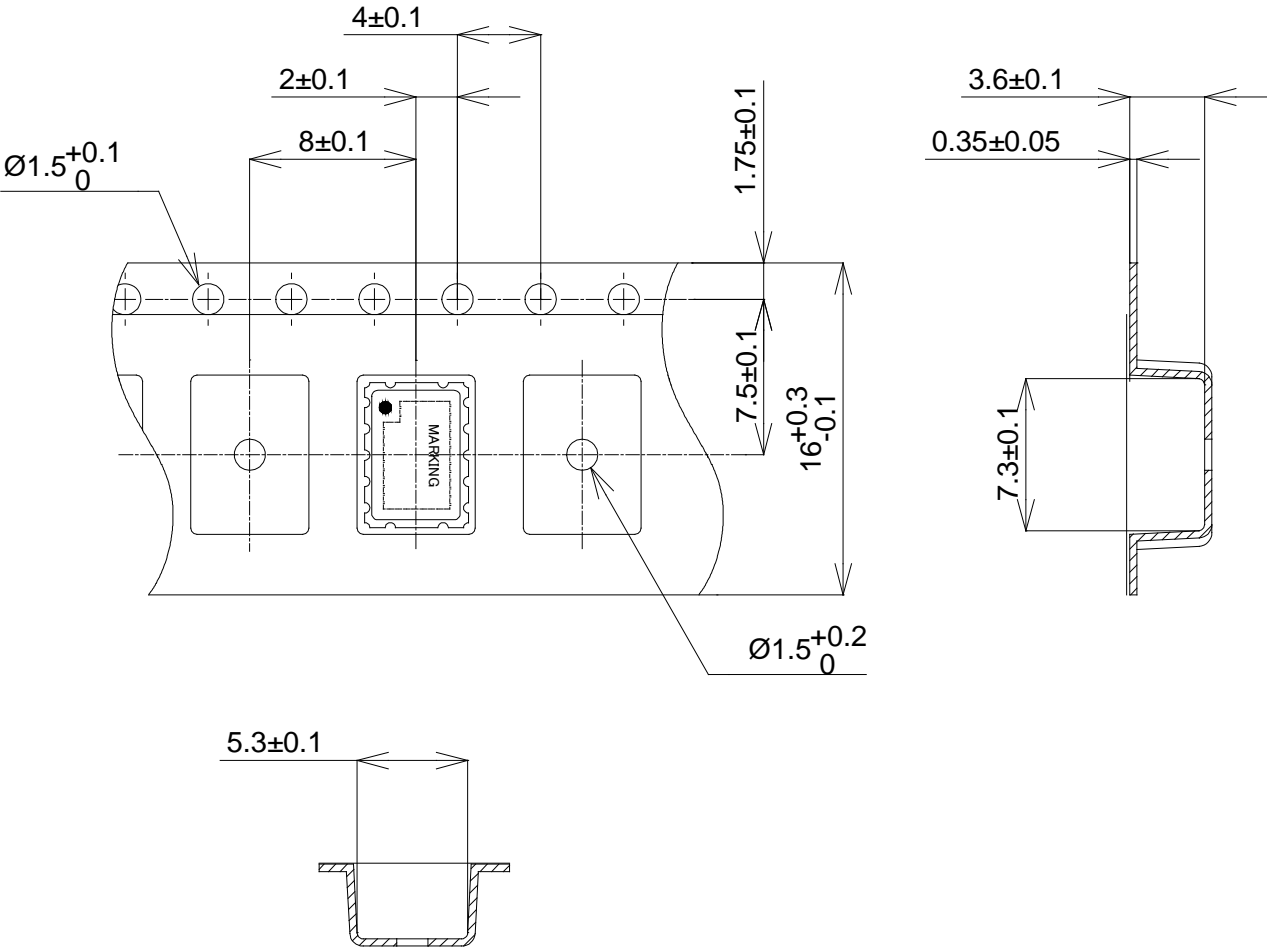

Handling precautions

1. Please do not add strong shock to the oscillator. In the time of transportation or installing the equipment, please do not drop or add shock to it. If strong shock is added, it may not operate normally. In that case, please use it after checking the characteristics.
2. Because of Oven Controlled Crystal Oscillator (OCXO), please do not place this product near heat sources, signal and noise sources that may affect the oscillator, and transmitter-receivers.
3. In OCXO, It is not recommended that some metal like a heat sink is placed on it directly, which is controlled by a specific high temperature, so that the characteristics cause unstable temperature control. Moreover, the ambient wind could affect characteristics by the same reason. The characteristic degradation by changing may occur according to ambient environment in the low temperature especially. Therefore, in the case of use of these products, please kindly do sufficient evaluation in advance on your side.
4. After soldering process, OCXO's characteristics may not be stable immediately because internal parts are influenced by the heat when soldering. For that reason, please avoid immediately using of these products after soldering and evaluate sufficiently in advance on your side.
5. If GND impedance of wiring pattern is high, OCXO's characteristics may not be stable because current consumption of OCXO greatly changes by the ambient temperature. In the case of use of these products, please kindly design GND impedance of wiring pattern to be sufficiently lower.
6. Placement of this product within the influenced area by magnetic field is not recommended because it may be affected magnetically. In the case of use of these products in such a situation, please kindly do sufficient evaluation in advance on your side.

Notes on use

1. Even if the appearance color etc. of the product differs by purchasing the component parts by more than two companies, there is no influence on the characteristics and reliability.
2. IN THE CASE OF THE FOLLOWING ITEMS, WE ARE NOT RESPONSIBLE FOR WARRANTY / COMPENSATION.
 - (1) WHEN PRODUCTS OF THIS SPECIFICATION ARE USED FOR EQUIPMENT RELATED TO HUMAN LIFE OR PROPERTY, IT IS THE RESPONSIBILITY OF THE CUSTOMER TO CONFIRM THE INFLUENCE ON THIS PRODUCT AND EQUIPMENT TO BE USED BEFOREHAND, CONDUCT NECESSARY SAFETY DESIGN (INCLUDING REDUNDANT DESIGN, MALFUNCTION PREVENTION DESIGN, etc.), PLEASE USE IT AFTER SECURING SUFFICIENT SAFETY OF EQUIPMENT.
 - 1.SAFETY-RELATED EQUIPMENT SUCH AS AUTOMOBILES, TRAINS, SHIPS, etc., OR EQUIPMENT DIRECTLY INVOLVED IN OPERATION
 - 2.AIRCRAFT EQUIPMENT
 - 3.SPACE EQUIPMENT
 - 4.MEDICAL EQUIPMENT
 - 5.MILITARY EQUIPMENT
 - 6.DISASTER PREVENTION / CRIME PREVENTION EQUIPMENT
 - 7.TRAFFIC LIGHT
 - 8.OTHER EQUIPMENT REQUIRING THE SAME PERFORMANCE AS THE ABOVE-MENTIONED EQUIPMENT
 - (2) IN CASES WHERE IT IS NOT INDICATED IN THE REQUESTED STANDARD AND IS USED UNDER CONDITIONS OF USE (INCLUDING CIRCUIT MARGIN etc.) THAT CAN NOT BE PREDICTED AT THE PRODUCTION STAGE.
 - (3) WHEN USING ULTRASONIC WELDING MACHINE. (THERE IS A POSSIBILITY THAT THE CHARACTERISTIC DEGRADATION IS CAUSED BY THE RESONANCE PHENOMENON OF THE PIEZOELECTRIC MATERIAL.
(EXAMPLE; CRYSTAL PIECE))

WE WILL NOT TAKE ANY RESPONSIBILITY FOR THE INFLUENCE OF THE CUSTOMERS' PROCESS.

SO, PLEASE SUFFICIENTLY EVALUATE AT A SAMPLE STEP WHEN YOU USE ULTRASONIC WELDING MACHINE.

(4) USING RESIN MOLD MAY AFFECT THE PRODUCT CHARACTERISTIC.

PLEASE MAKE SURE TO TELL OUR SALES CONTACT WHEN YOU USE RESIN MOLD. WE WILL PERFORM INDIVIDUAL CORRESPONDENCE ABOUT A DELIVERY SPECIFICATION AND AN EVALUATION METHOD.

IN ADDITION, IF YOU USE RESIN MOLD WITHOUT CONTACTING US, AND CAUSES DAMAGES AGAINST A CUSTOMER OR A THIRD PARTY, WE WILL NOT BE LIABLE FOR THE DAMAGES AND OTHER RESPONSIBILITIES BECAUSE WE CONSIDER IT IS UNDER SELF-RESPONSIBILITY USING RESIN MOLD.

WE WILL NOT TAKE ANY RESPONSIBILITY FOR THE INFLUENCE OF THE CUSTOMERS' PROCESS. PLEASE EFFICIENTLY EVALUATE AT A SAMPLE STEP WHEN YOU USE RESIN MOLD.

(5) WHEN PERFORMING IMPROPER HANDLING THAT EXCEEDS THE GUARANTEED RANGE.

(6) WHEN USING THIS PRODUCT, PLEASE INSERT A BYPASS CAPACITOR BETWEEN THE POWER SUPPLY AND GND.

(CLOSER TO THE PRODUCT TERMINAL IS DESIRABLE.)

THE BYPASS CAPACITOR VALUES SHOWN IN OUR SPECIFICATIONS AND DRAWING ARE FOR REFERENCE ONLY.

3. This product can not be used for automotive applications.

Notes on storage

1. When storing the product in high temperature and high humidity condition for a long time, product characteristics (solderability etc.) and packaging condition may be deteriorated. Please store product at temperature +5 °C~+35 °C, humidity 85% RH or less. The product is an electronic component, so please do not storage under a dewing state.
2. The product storage deadline is 12 months after delivery in unopened state. Please use within storage deadline. If you exceed storage deadline, please check the product characteristics etc, please use.

Handling of this document and other requests

Please refer to the " Site Guidance" on our website for the handling of information contained in this document. (<https://www.ndk.com/en/terms/>)